



Industrial I

Katalog 2023



SpektraLED GmbH

Erlau 5 | 4770 Andorf, Austria

+43 (0) 7766 50032 | office@spektraled.at

www.spektraled.at



CONTENTS

LED FLOOD LIGHT Series

LED PROJECTING LIGHT Series

LED HIGHBAY LIGHT Series



P 6-23

OUTDOOR



P 24-33



P 34-41

INDOOR



VENUS

Series (SPE-FLE/FLM)

P 6-9

- Available from 30W to 100W
- Designed for applications in price competitive market



HERCULES

Series (SPE-PLS)

P 24-27

- Available from 400W up to 1500W, are the most powerful LED lighting products in the market, offering ultra-high lumen output.
- LED Sports Light
- The whole series is perfectly suited for mounting on highmasts or lighting towers



AURORA

Series (SPE-HBR)

P 34-37

- Available from 70W to 200W
- Best cost-performance ratio with excellent long term reliability
- Very high lumen output at 145 lm/W efficacy
- Integrated with Meanwell HBG driver



APOLLO

Series (SPE-FL)

P 10-18

- Available from 60W to 800W
- Our hottest flagship product
- Engineered for high-end outdoor lighting market
- **Optionall LED COLOR: RGB or single Color R/G/B**



TITAN

Series (SPE-PL)

P 28-33

- Available from 60W to 360W
- Powerful and compact, the PL series is designed to provide the best illumination effect for the next generation of exterior, architectural applications.
- **Optionall LED COLOR: RGB**
Red, Green, Blue, White



AURORA G2

Series (SPE-HBR2)

P 38-41

- Available from 70W to 300W



JUPITER

Series (SPE-FLS)

P 19-23

- Available from 400W to 1500W
- The most premium product in the market
- Designed for professional lighting market such as stadium lighting



AURORA

with Reflector

LED CONTINUOUS LIGHTING System



P 42-55 INDOOR



PEGASUS

Series (SPE-FB)

P42-45

- Available from 60W to 300W
- Flatbays typical energy savings of over 60% compared with traditional light fixtures can be further improved with intelligent dimming.
- Available with either 1-10V or DALI dimming and compatible with all leading sensor manufacturers



HERMES

Series (SPE-LUM)

P 46-55

Available from 30W to 60W / IP20
SpektraLED's LED Continuous Lighting System (CLS), also called Trunking System, is engineered to deliver unparalleled lighting performance and bring an elegant, understated design element to a work or retail space.

LED MODULAR Series



P 56-69



Modular Family

PANDORA

P 56-59

- 130lm / w designed to meet and exceed industry performance standards
- WATERPROOF:
Unique silicone based waterproof technology enables instant IP65 rating for the light engines

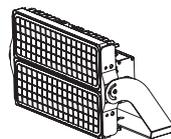

Flood Light

Series (SPE-MFL)

P 60-61

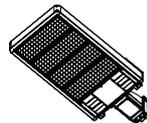

Flood Light

Series (SPE-MCP)

P 62-63

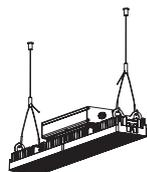

Highbay

Series (SPE-MHB)

P 64-65



Canopy Light

Series (SPE-MCA)

P 66-69

Lichtsteuerung

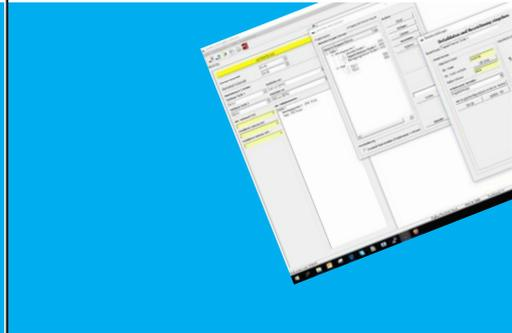

P 70-71



Lichtsteuerung

mit Funktechnik
(ZigBee 2,4 GHz)

P 70-71

VENUS series

SPE - FLE / FLM

Available from 30W to 100W IP65

Designed for applications in price competitive market

- * Building facades
- * Security
- * Industrial
- * Signage & Billboards
- * Landscape
- * Commercial spaces





Comparison



**LED
Flood Light**

VS



**Metal
Halide**

**Energy Saving
60%**

30W / 40W / 50W

60W / 80W

100W

70W

150W

250W

Design Innovation



ROI Calculation

- 100W LED flood light to replace 250W Metal Halide
- Each LED flood light save 150W
- Assuming 12 hours daily operation time, then each day saves 1.8k/WH
- Annual saving is 657k/WH
- Initial price difference of LED flood light and Metal Halide is around USD 100-120
- Assuming electricity bill USD 0.16/kWH Therefore, the payment period is around 1 year
- Due to long service life (>50,000 hours), the user can extra benefit on saving maintenance cost



VENUS Series SPE-FLE / SPE-FLM

IP65



Parameter

Model No.	SPE-FLE-030 SPE-FLM-030	SPE-FLE-040 SPE-FLM-040	SPE-FLE-050 SPE-FLM-050	SPE-FLE-060 SPE-FLM-060
Input Voltage	100-305VAC	100-305VAC	100-305VAC	100-305VAC
LED Power	30 W	40 W	50 W	60 W
System Power	33 W	44 W	55 W	66 W
Luminous Flux	3,600 lm / 3,300lm (FLM)	4,800 lm / 4,400lm (FLM)	6,000 lm / 5,500lm (FLM)	7,200 lm / 6,600lm (FLM)
System Efficacy	110 lm/W	110 lm/W	110 lm/W	110 lm/W
Beam Angle	SPE-FLE: 15°x15° / 30°x30° / 60°x60° / 90°x90° / 60°x 90° / 85°x45° / 85°x 90° / 60°x135° / 85°x 135°			SPE-FLM: 120°
CCT (K)	3000 / 4000 / 5000 / 6500	3000 / 4000 / 5000 / 6500	3000 / 4000 / 5000 / 6500	3000 / 4000 / 5000 / 6500
CRI	80	80	80	80
Dimmable	1-10V /DALI	1-10V /DALI	1-10V /DALI	1-10V /DALI
Power Factor	> 0.90	> 0.90	> 0.90	> 0.90
Lifespan	50,000 H	50,000 H	50,000 H	50,000 H
Operating Temp.	-40°C ~ + 45°C	-40°C ~ + 45°C	-40°C ~ + 45°C	-40°C ~ + 45°C
Dimension	267 x 220 x 173 mm	267 x 220 x 173 mm	267 x 267 x 173 mm	267 x 267 x 173 mm
Weight (kg)	6,2	6,2	8	8
Certifications	CE, CB, SAA, ETL	CE, CB, SAA, ETL	CE, CB, SAA, ETL	CE, CB, SAA, ETL

Photometrics

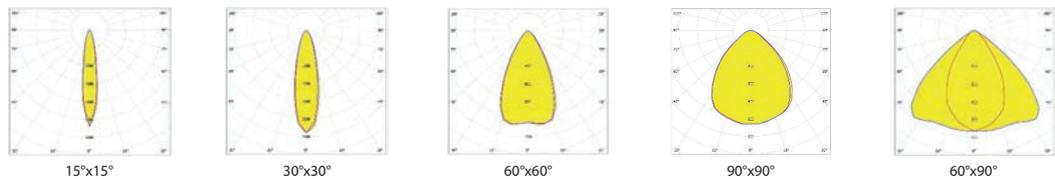

Dimensions (mm)

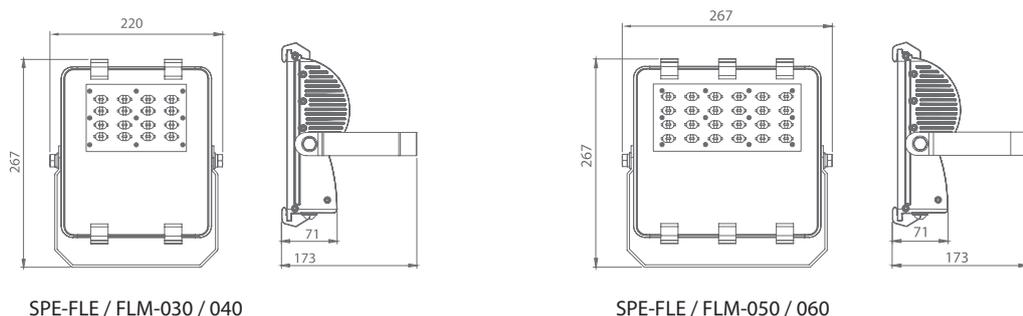



Parameter

	SPE-FLE-080 SPE-FLM-080	SPE-FLE-100 SPE-FLM-100
Model No.	SPE-FLE-080 SPE-FLM-080	SPE-FLE-100 SPE-FLM-100
Input Voltage	100-305V AC	100-305V AC
LED Power	80 W	100 W
System Power	88 W	110 W
Luminous Flux	9,600 lm / 8,800lm (FLM)	12,000 lm / 11,100lm (FLM)
System Efficacy	110 lm/W	110 lm/W
Beam Angle	SPE-FLE: 15°x15° / 30°x30° / 60°x60° / 90°x90° / 60°x 90° / 85°x45° / 85°x 90° / 60°x135° / 85°x 135° SPE-FLM: 120°	
CCT (K)	3000 / 4000 / 5000 / 6500	3000 / 4000 / 5000 / 6500
CRI	80	80
Dimmable	1-10V /DALI	1-10V /DALI
Power Factor	> 0.90	> 0.90
Lifespan	50,000 H	50,000 H
Operating Temp.	-40°C ~ + 45°C	-40°C ~ + 45°C
Dimension	267 x 322 x 173 mm	267 x 322 x 173 mm
Weight (kg)	9,6	9,6
Certifications	CE, CB, SAA, ETL	CE, CB, SAA, ETL

Photometrics

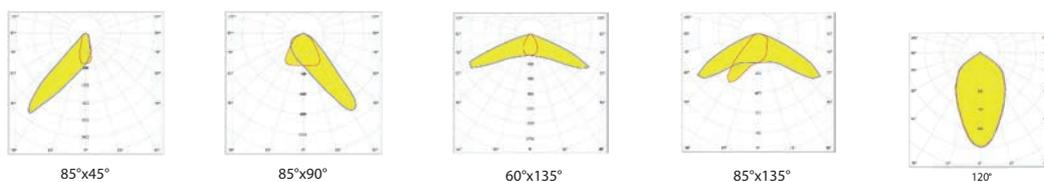

Dimensions (mm)

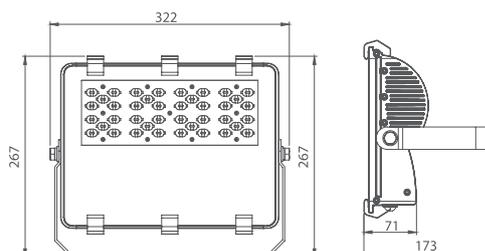

SPE-FLE / FLM-080 / 100

APOLLO series

(SPE - FL)

Available from 60W to 800W IP65

Designed for sports, site and area applications such as:

- * Class I, II & III outdoor sports fields & courts
- * Indoor arenas
- * Signage & Billboards
- * Ports & Depots
- * Heavy Industrial and wet locations

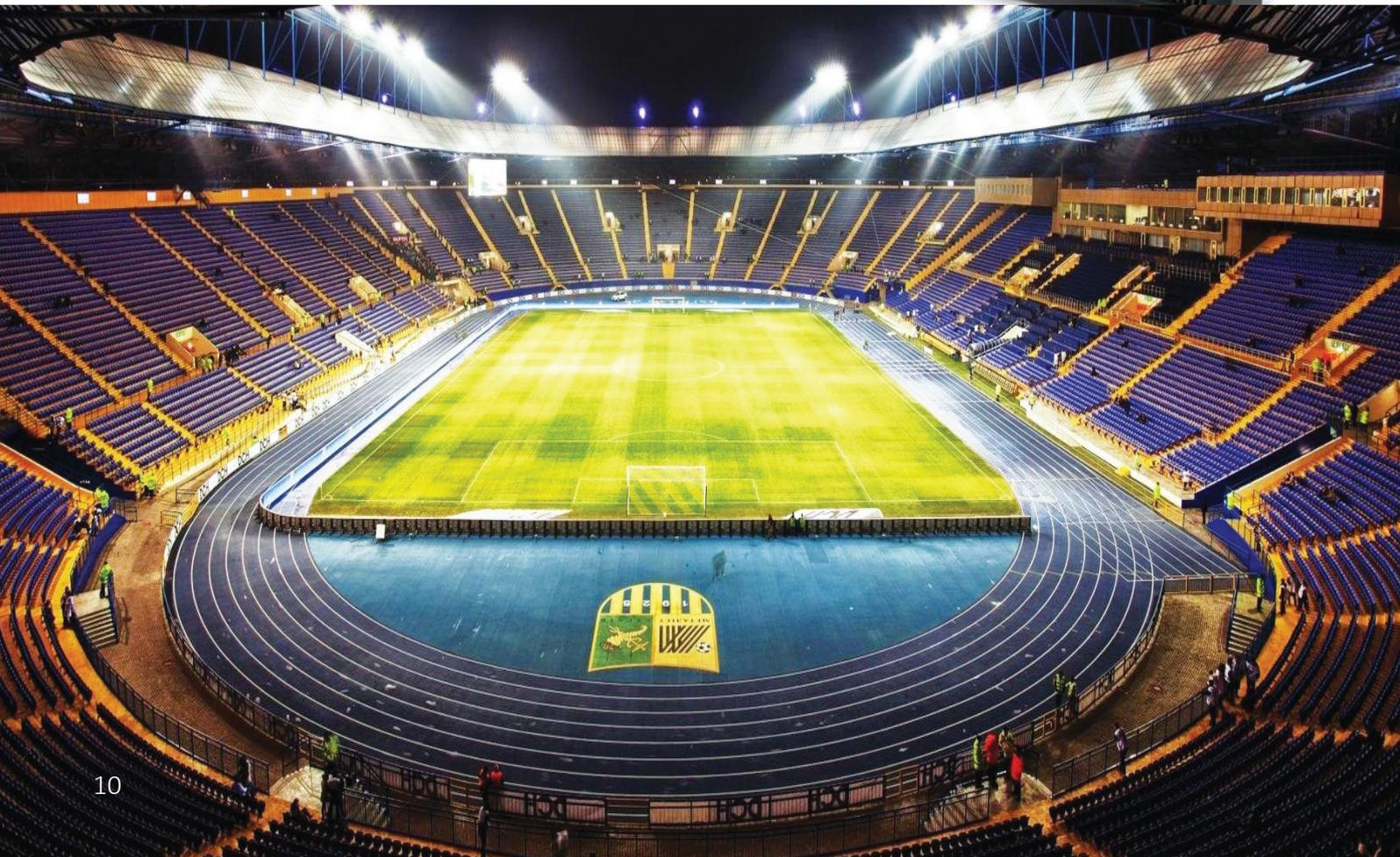



LED vs Metal Halide Replacement Table



**LED
Flood Light**

VS

**Metal
Halide
Flood Light**

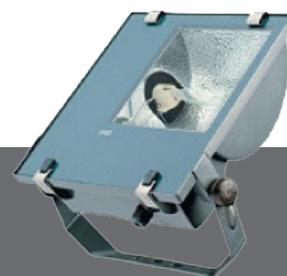

**Energy Saving
60%**

60W / 80W	150W
100W / 150W	250W
200W / 250W	400W
300W / 350W	750W
400W / 500W	1000W
600W	1500W
800W	2000W

Design Innovation

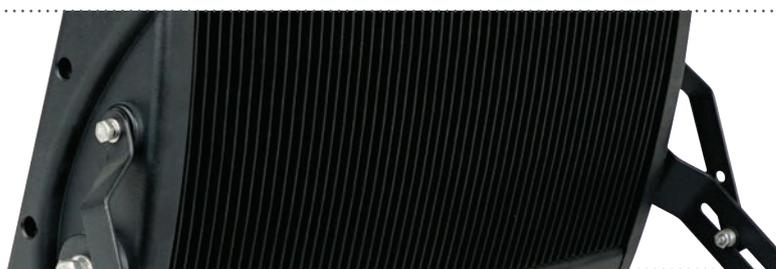

Fold-Fin Heatsink (FFH) technology

- formed by thin aluminum sheets and pressed into the desired fin structures by fully automated machines
- different parts of heatsink are then soldered together via a high temperature furnace.
- resulting in a heatsink with large total surface area and extremely light weight.

Air ventilation housing design

- the housing is designed in a way to allow very effective air flow across the heatsink.
- it helps to bring the heat away from LED light source by natural convection.

Distributed heat source

- distributed light source panel configuration to spread the heat source over large area.
- greatly reduced thermal density helps to lower the LED junction temperature.

APOLLO Series SPE-FL

IP65



Parameter

Model No.	SPE-FL-060	SPE-FL-080	SPE-FL-100
Input Voltage	100-305V AC	100-305V AC	100-305V AC
LED Power	60 W	80 W	100W
System Power	66 W	90 W	110W
Luminous Flux	7,200 lm	9,600 lm	12,000 lm
System Efficacy	110 lm/W	110 lm/W	110 lm/W
Beam Angle	15°x15° / 30°x30° / 60°x60° / 90°x90° / 60°x90° / 85°x45° / 85°x90° / 60°x135° / 85°x 135°		
CCT (K)	3000 / 4000 / 5000 / 6500	3000 / 4000 / 5000 / 6500	3000 / 4000 / 5000 / 6500
CRI	80	80	80
Dimmable	1-10V /DALI	1-10V /DALI	1-10V /DALI
Power Factor	> 0.90	> 0.90	> 0.90
Lifespan	50,000 H	50,000 H	50,000 H
Operating Temp.	-40°C ~ + 45°C	-40°C ~ + 45°C	-40°C ~ + 45°C
Dimension	327 x 91x 366 mm	327 x 91 x 366 mm	387 x 91 x 366 mm
Weight (kg)	5	6	6,5
Certifications	CE, CB, SAA, ETL	CE, CB, SAA, ETL	CE, CB, SAA, ETL

Photometrics

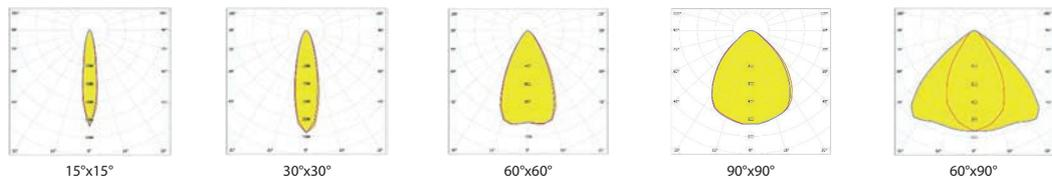

Dimensions (mm)

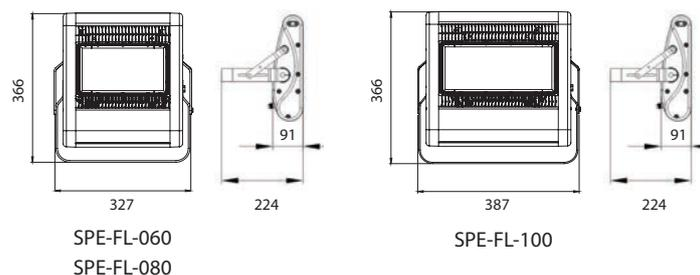



Parameter

Model No.	SPE-FL-120	SPE-FL-150	SPE-FL-200
Input Voltage	100-305V AC	100-305V AC	100-305V AC
LED Power	120 W	150 W	200W
System Power	135 W	170 W	220W
Luminous Flux	14,000 lm	18,000 lm	24,000 lm
System Efficacy	110 lm/W	110 lm/W	110 lm/W
Beam Angle	15°x15° / 30°x30° / 60°x60° / 90°x90° / 60°x90° / 85°x45° / 85°x90° / 60°x135° / 85°x 135°		
CCT (K)	3000 / 4000 / 5000 / 6500	3000 / 4000 / 5000 / 6500	3000 / 4000 / 5000 / 6500
CRI	80	80	80
Dimmable	1-10V /DALI	1-10V /DALI	1-10V /DALI
Power Factor	> 0.90	> 0.90	> 0.90
Lifespan	50,000 H	50,000 H	50,000 H
Operating Temp.	-40°C ~ + 45°C	-40°C ~ + 45°C	-40°C ~ + 45°C
Dimension	387 x 91x 366 mm	387 x 91 x 366 mm	507 x 91 x 366 mm
Weight (kg)	6,5	8	8
Certifications	CE, CB, SAA, ETL	CE, CB, SAA, ETL	CE, CB, SAA, ETL

Photometrics

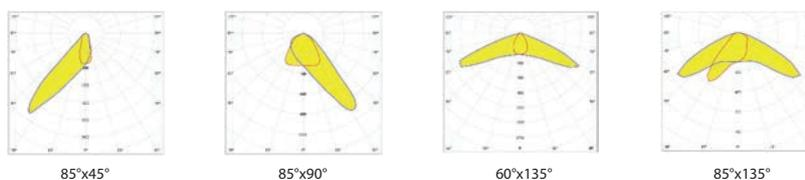

Dimensions (mm)

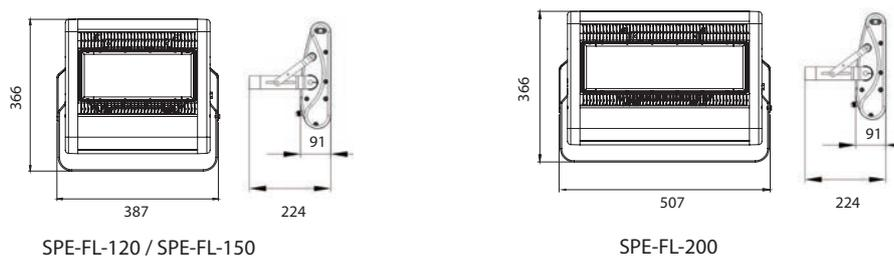

APOLLO Series SPE-FL

IP65



Parameter

Model No.	SPE-FL-250	SPE-FL-300	SPE-FL-350	SPE-FL-400
Input Voltage	100-305VAC	100-305VAC	100-305VAC	100-305VAC
LED Power	250 W	300 W	350 W	400 W
System Power	280 W	330 W	390 W	440 W
Luminous Flux	30,000 lm	36,000 lm	42,000 lm	48,000 lm
System Efficacy	110 lm/W	110 lm/W	110 lm/W	110 lm/W
Beam Angle	15°x15° / 30°x30° / 60°x60° / 90°x90° / 60°x90° / 85°x45° / 85°x90° / 60°x135° 85°x 135°			
CCT (K)	3000 / 4000 / 5000 / 6500	3000 / 4000 / 5000 / 6500	3000 / 4000 / 5000 / 6500	3000 / 4000 / 5000 / 6500
CRI	80	80	80	80
Dimmable	1-10V /DALI	1-10V /DALI	1-10V /DALI	1-10V /DALI
Power Factor	> 0.90	> 0.90	> 0.90	> 0.90
Lifespan	50,000 H	50,000 H	50,000 H	50,000 H
Operating Temp.	-40°C ~ + 45°C	-40°C ~ + 45°C	-40°C ~ + 45°C	-40°C ~ + 45°C
Dimension	567 x 91x 366 mm	567 x 91x 366 mm	533 x 91x 621 mm	533 x 91x 621 mm
Weight (kg)	9	17	17,5	19
Certifications	CE, CB, SAA, ETL	CE, CB, SAA, ETL	CE, CB, SAA, ETL	CE, CB, SAA, ETL

Photometrics

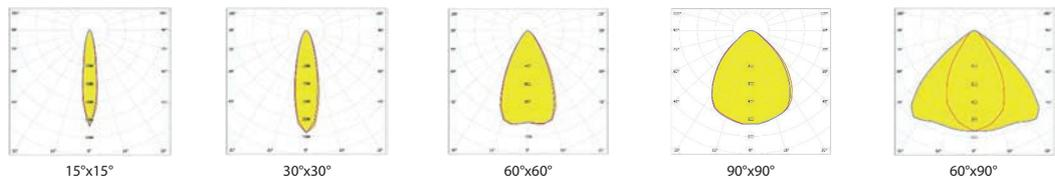

Dimensions (mm)

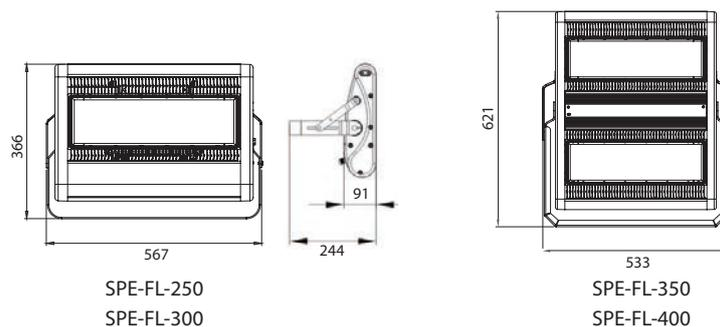



Parameter

Model No.	SPE-FL-500	SPE-FL-600	SPE-FL-800
Input Voltage	100-305V AC	100-305V AC	100-305V AC
LED Power	500 W	580 W	800W
System Power	550 W	640 W	880W
Luminous Flux	60,000 lm	70,500 lm	96,800 lm
System Efficacy	110 lm/W	110 lm/W	110 lm/W
Beam Angle	15°x15° / 30°x30° / 60°x60° / 90°x90° / 60°x90° / 85°x45° / 85°x90° / 60°x135° / 85°x 135°		
CCT (K)	3000 / 4000 / 5000 / 6500	3000 / 4000 / 5000 / 6500	3000 / 4000 / 5000 / 6500
CRI	80	80	80
Dimmable	1-10V /DALI	1-10V /DALI	1-10V /DALI
Power Factor	> 0.90	> 0.90	> 0.90
Lifespan	50,000 H	50,000 H	50,000 H
Operating Temp.	-40°C ~ + 45°C	-40°C ~ + 45°C	-40°C ~ + 45°C
Dimension	593 x 117x 621 mm	593 x 117x 621 mm	811 x 117x 606 mm
Weight (kg)	27	27,5	29,5
Certifications	CE, CB, SAA, ETL	CE, CB, SAA, ETL	CE, CB, SAA, ETL

Photometrics

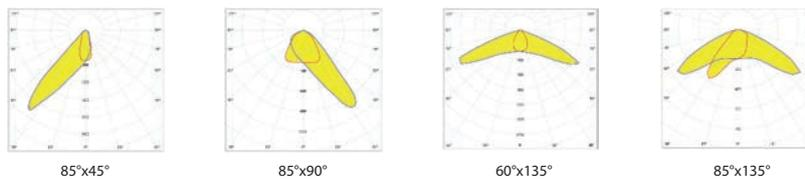

Dimensions (mm)

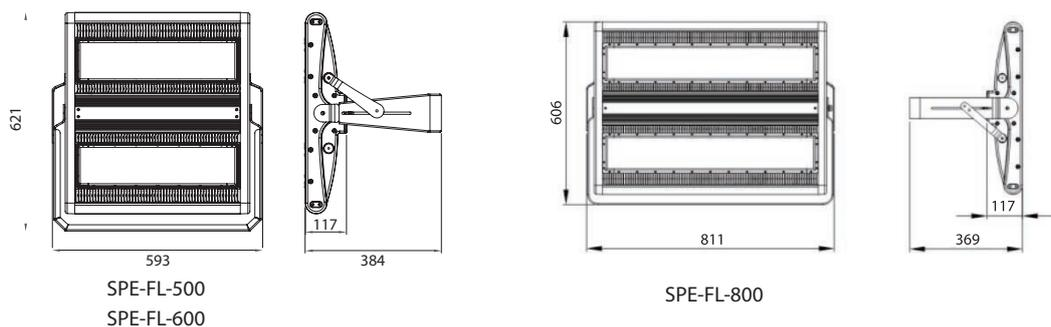

Thermal Performance

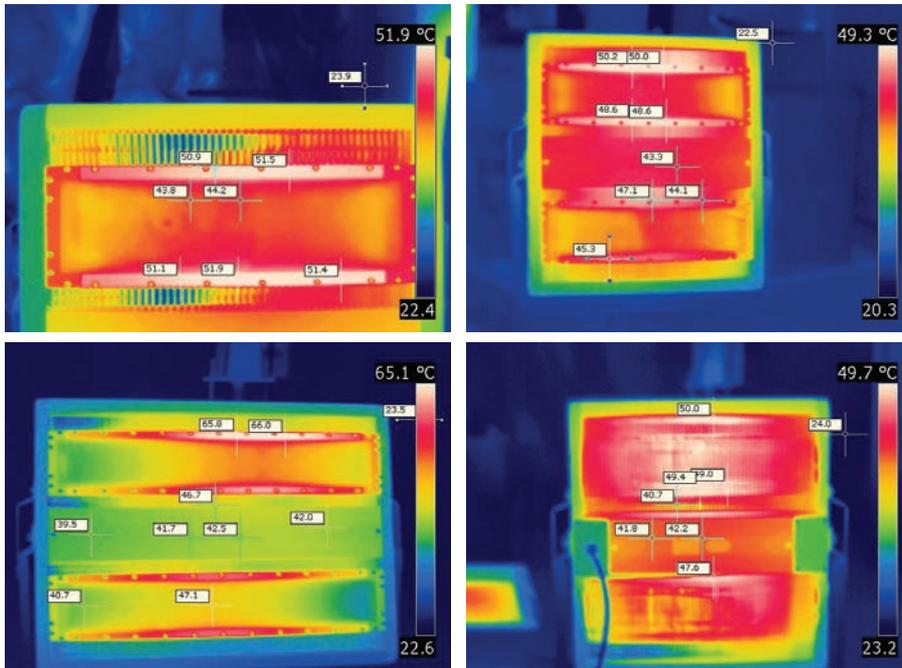

All of our products are designed for superior thermal performance to ensure long lifetime operation.

Installation Configuration Schematics

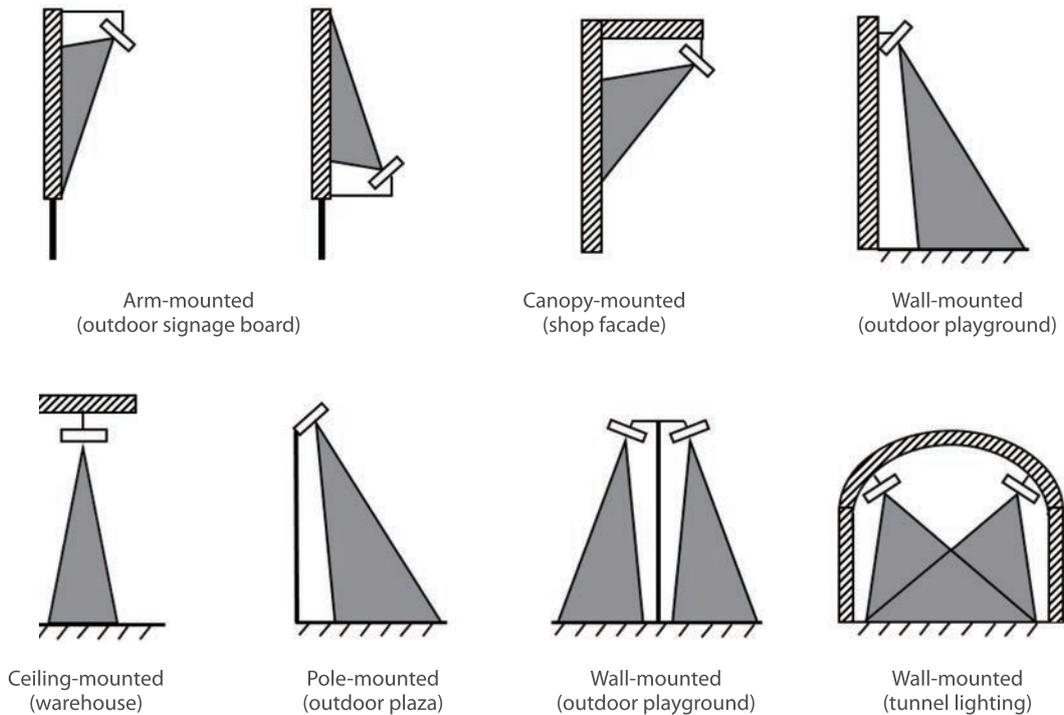



Parameter

Model No.	Reflector Type	LED Light Source	Color Temp	Dimming Control	IP Rating
SPE-FL-060	15°x15°	Lumileds / Cree / OSRAM	3000K	Dimmable (PWM input) / (1-10V input)	IP65
SPE-FL-080	30°x30°		4000K		
SPE-FL-100	60°x60°		5000K		
SPE-FL-120	90°x90°		6500K		
SPE-FL-150	60°x90°			DAI	
SPE-FL-200	85°x45°				
SPE-FL-250	85°x90°			Non-Dimmable	
SPE-FL-300	60°x135°				
SPE-FL-350	(symmetric)				
SPE-FL-400	85°x135°				
SPE-FL-600	(asymmetric)				
SPE-FL-800					

Note:

- (1) Other color tempature available upon request
- (2) All models are IP65 rating
- (3) Available housing color: Black / White / Grey

Accessories Order Information



Item
15°x15° lens

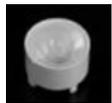

Item
40°x40° lens

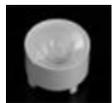

Item
30°x30° lens

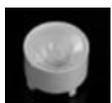

Item
60°x60° lens



Item
60°x135° lens
(symmetric)

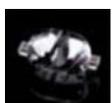

Item
85°x135° lens
(asymmetric)

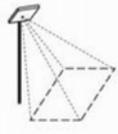
Lens Type	Light Patten	Projection Schematic
Round Type	 round	
Rectangular	 symmetric	
	 asymmetric	

APOLLO COLOR

RGB series

Available from 60W to 600W IP65

- Light Source: Cree XPE Color
- Supply Voltage: 90-305 VAC
- Single LED Current: 500mA (R/G/B)
- Control Protocol: Standard DMX512
- LED Color: **RGB**, or single color **R/G/B**
- Beam Angle: 15°x15° / 30°x30° / 60°x60° / 85°x135°
- Lifespan: 30,000 hrs
- Operating Temp: -25°C to +45°C



Parameter

Model No.	System Power	LED Quantity	Weight	Dimension
SPE-FL-060C	60W	RGB x 10 pcs	6.0 kg	327 x 366 x 244 mm
SPE-FL-100C	100W	RGB x 18 pcs	8.5 kg	387 x 366 x 244 mm
SPE-FL-150C	150W	RGB x 30 pcs	10.0 kg	507 x 366 x 244 mm
SPE-FL-200C	200W	RGB x 36 pcs	11.5 kg	507 x 366 x 244 mm
SPE-FL-300C	300W	RGB x 48 pcs	19.5 kg	533 x 606 x 384 mm
SPE-FL-400C	400W	RGB x 66 pcs	21.0 kg	533 x 606 x 384 mm
SPE-FL-500C	500W	RGB x 78 pcs	29.0 kg	833 x 606 x 384 mm
SPE-FL-600C	600W	RGB x 96 pcs	30.0 kg	833 x 606 x 384 mm



JUPITER series

(SPE - FLS)

Available from 400W to 1500W IP65

SpektraLED's most powerful LED product, Jupiter series, is designed to provide the best illumination effect for the next generation of exterior, architectural and sports field applications. By combining the proprietary thermal management system with specially designed optics and an elegant fixture, it is unique product in the outdoor LED lighting market.

Designed for applications such as:

- * Hight Mast
- * Sports stadiums
- * Ports
- * Indoor arenas
- * Railyards
- * Airport Apron



JUPITER Series SPE-FLS

IP65



Parameter

Model No.	SPE-FLS-400	SPE-FLS-500
Input Voltage	100-305V AC	100-305V AC
LED Power	400 W	500 W
System Power	440 W	550 W
Luminous Flux	48,000 lm	60,000 lm
System Efficacy	110 lm/W	110 lm/W
Beam Angle	15°x15° / 30°x30° / 60°x60° / 90°x90° / 60°x90° / 85°x45° / 85°x90° / 60°x135° / 85°x 135°	
CCT (K)	3000 / 4000 / 5000 / 6500	3000 / 4000 / 5000 / 6500
CRI	80	80
Dimmable	1-10V /DALI	1-10V /DALI
Power Factor	> 0.90	> 0.90
Lifespan	50,000 H	50,000 H
Operating Temp.	-40°C ~ + 45°C	-40°C ~ + 45°C
Dimension	742 x 528 x 166 mm	832 x 528 x 166 mm
Weight (kg)	23,6	27
Certifications	CE, CB, SAA, ETL	CE, CB, SAA, ETL

Photometrics

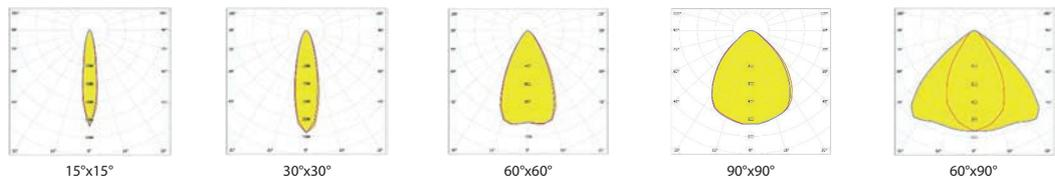

Dimensions (mm)

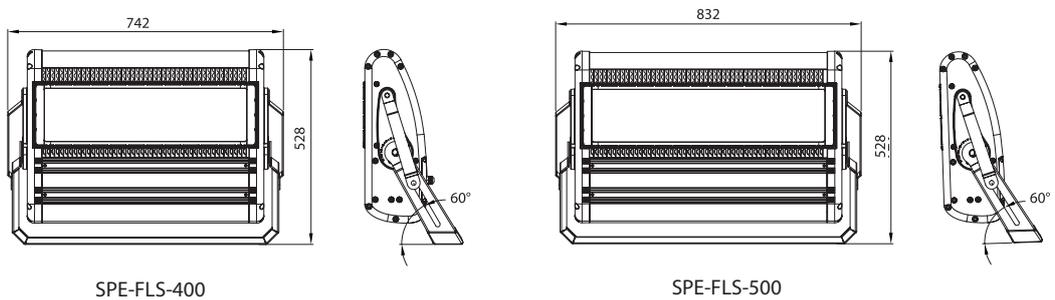



Parameter

Model No.	SPE-FLS-600	SPE-FLS-800
Input Voltage	100-305V AC	100-305V AC
LED Power	580 W	800 W
System Power	640 W	880 W
Luminous Flux	70,500 lm	92,000 lm
System Efficacy	110 lm/W	110 lm/W
Beam Angle	15°x15° / 30°x30° / 60°x60° / 90°x90° / 60°x90° / 85°x45° / 85°x90° / 60°x135° / 85°x 135°	
CCT (K)	3000 / 4000 / 5000 / 6500	3000 / 4000 / 5000 / 6500
CRI	80	80
Dimmable	1-10V /DALI	1-10V /DALI
Power Factor	> 0.90	> 0.90
Lifespan	50,000 H	50,000 H
Operating Temp.	-40°C ~ + 45°C	-40°C ~ + 45°C
Dimension	623 x 724 x 166 mm	743 x 724 x 166 mm
Weight (kg)	28	35,8
Certifications	CE, CB, SAA, ETL	CE, CB, SAA, ETL

Photometrics

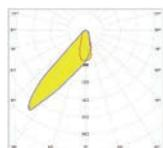

85°x45°

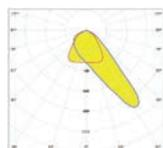

85°x90°

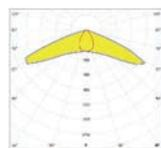

60°x135°

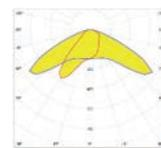

85°x135°

Dimensions (mm)

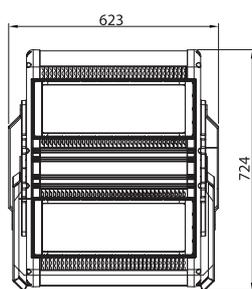

SPE-FLS-600

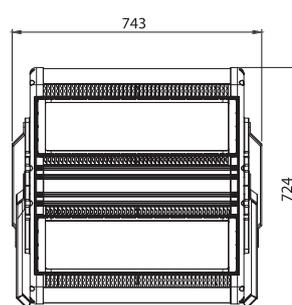
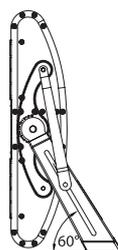

SPE-FLS-800

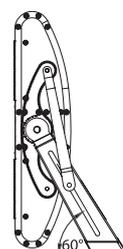

JUPITER Series SPE-FLS

IP65



Parameter

	SPE-FLS-1000	SPE-FLS-1500
Model No.	SPE-FLS-1000	SPE-FLS-1500
Input Voltage	100-305V AC	100-305V AC
LED Power	1000 W	1400 W
System Power	1100 W	1550 W
Luminous Flux	116,000 lm	162,000 lm
System Efficacy	110 lm/W	110 lm/W
Beam Angle	15°x15° / 30°x30° / 60°x60° / 90°x90° / 60°x90° / 85°x45° / 85°x90° / 60°x135° / 85°x 135°	
CCT (K)	3000 / 4000 / 5000 / 6500	3000 / 4000 / 5000 / 6500
CRI	80	80
Dimmable	1-10V /DALI	1-10V /DALI
Power Factor	> 0.90	> 0.90
Lifespan	50,000 H	50,000 H
Operating Temp.	-40°C ~ + 45°C	-40°C ~ + 45°C
Dimension	743 x 724 x 166 mm	833 x 724 x 166 mm
Weight (kg)	35,8	41
Certifications	CE, CB, SAA, ETL	CE, CB, SAA, ETL

Photometrics

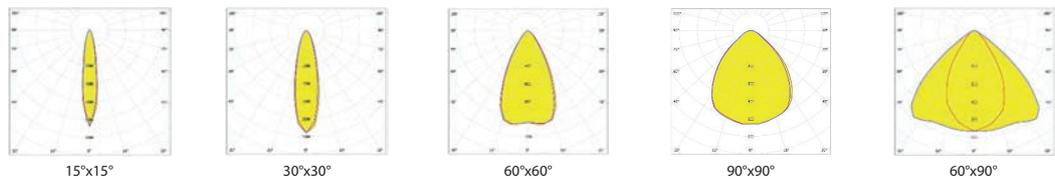

Photometrics

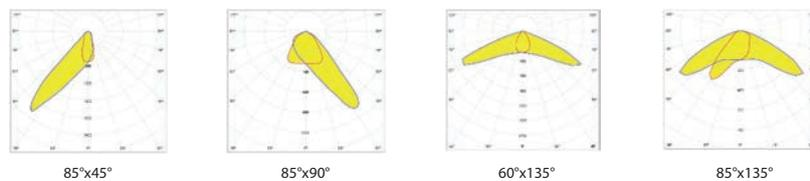



Dimensions (mm)

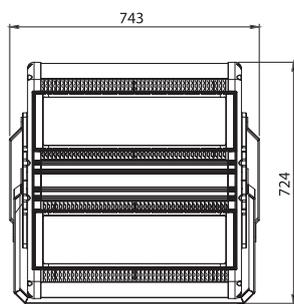

SPE-FLS-1000

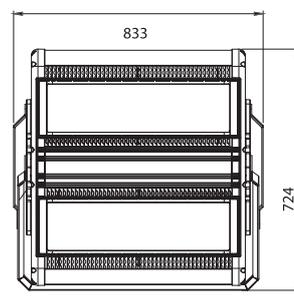
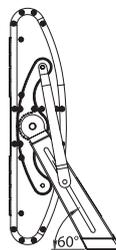

SPE-FLS-1500

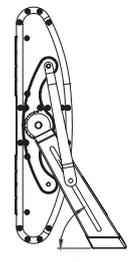

HERCULES series

(SPE - PLS)

Available from 400W to 1500W IP65

Designed for applications such as:

- * Hight Mast
- * Sports stadiums
- * Ports
- * Indoor arenas
- * Railyards
- * Airport Apron



LED SPORTS LIGHTING





Design Innovation



LED is creating a revolution in the world of lighting. Among many emerging applications for LED, sports lighting is one of the many rapidly growing markets. SpektraLED is at the forefront with our industry leading LED Luminaires and our brand new series of LED sports lighters have been designed to serve the most challenging lighting requirements in this area.

Available from 400W up to 1500W, HERCULES (SPE-PLS) Series are the most powerful LED lighting products in the market, offering ultra-high lumen output. The whole series is perfectly suited for mounting on highmasts or lighting towers and the custom designed optics offer a variety of specialized beam patterns for the optimum performance in any sports lighting application.

Accessories

Sensor compatible

Bracket design can be custom made for different sensors (ordered separately)

Aiming Laser

For simple aiming when installing

Bullseye

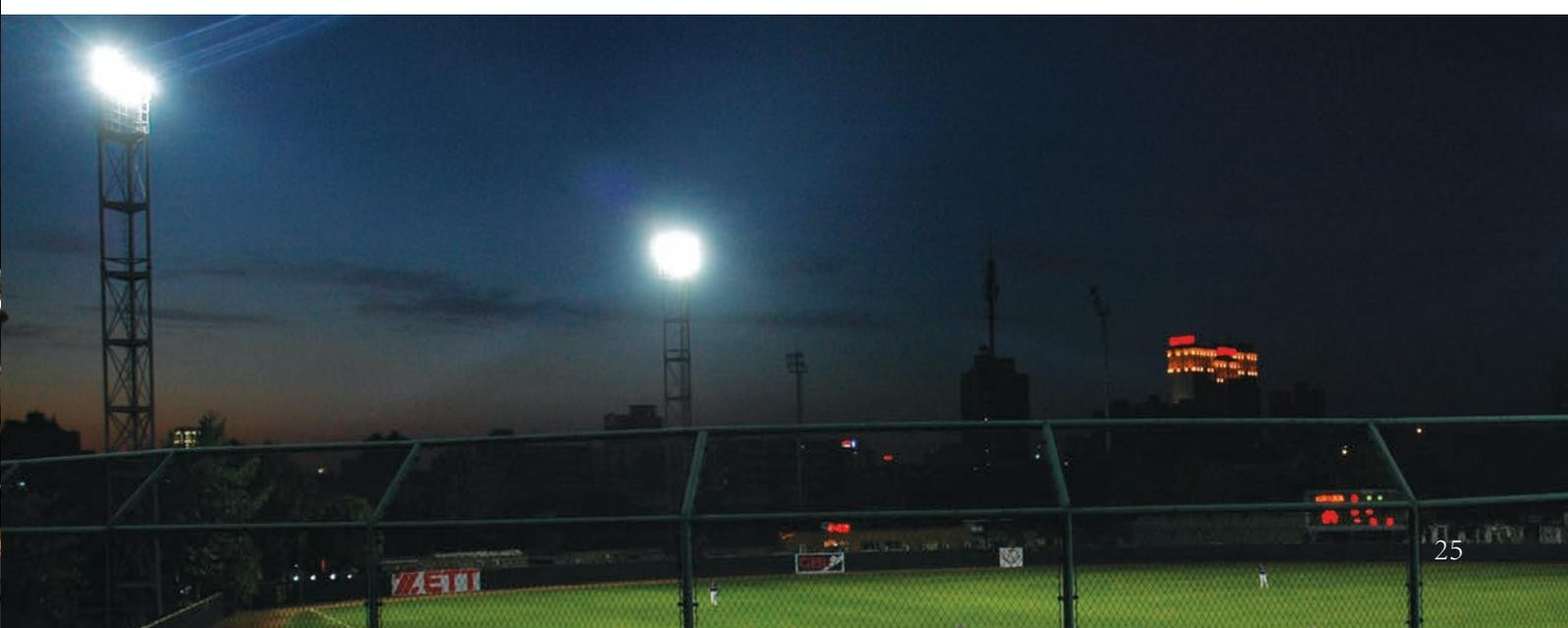

HERCULES Series SPE-PLS

IP65



Parameter

Model No.	SPE-PLS-400	SPE-PLS-600
Input Voltage	100-305V AC	100-305V AC
LED Power	400 W	600 W
System Power	440 W	660 W
Luminous Flux	46,000 lm	69,000 lm
System Efficacy	105 lm/W	105 lm/W
Beam Angle	10°x10° / 15°x15° / 30°x30° / 60°x60°	
CCT (K)	3000 / 4000 / 5000 / 6500	3000 / 4000 / 5000 / 6500
CRI	80	80
Dimmable	1-10V /DALI	1-10V /DALI
Power Factor	> 0.90	> 0.90
Lifespan	50,000 H	50,000 H
Operating Temp.	-40°C ~ + 45°C	-40°C ~ + 45°C
Dimension	533 x 365 x 518 mm	533 x 365 x 518 mm
Weight (kg)	20	20
Certifications	CE, CB, SAA, ETL	CE, CB, SAA, ETL

Photometrics

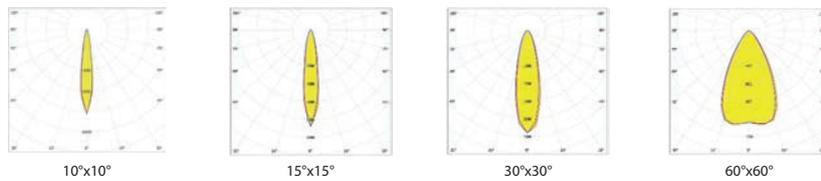

Dimensions (mm)

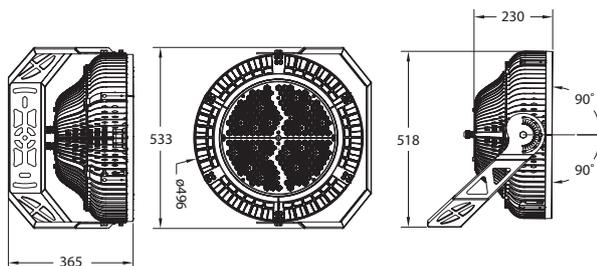

SPE-PLS-400 / SPE-PLS-600



Parameter

Model No.	SPE-PLS-800	SPE-PLS-1000	SPE-PLS-1500
Input Voltage	100-305V AC	100-305V AC	100-305V AC
LED Power	800 W	1000 W	1400W
System Power	880 W	1100 W	1550W
Luminous Flux	92,000 lm	115,500 lm	162,800 lm
System Efficacy	105 lm/W	105 lm/W	105 lm/W
Beam Angle	10°x10° / 15°x15° / 30°x30° / 60°x60°		
CCT (K)	3000 / 4000 / 5000 / 6500	3000 / 4000 / 5000 / 6500	3000 / 4000 / 5000 / 6500
CRI	80	80	80
Dimmable	1-10V /DALI	1-10V /DALI	1-10V /DALI
Power Factor	> 0.90	> 0.90	> 0.90
Lifespan	50,000 H	50,000 H	50,000 H
Operating Temp.	-40°C ~ + 45°C	-40°C ~ + 45°C	-40°C ~ + 45°C
Dimension	643 x 455 x 565 mm	643 x 455 x 565 mm	643 x 455 x 565 mm
Weight (kg)	31	31	31
Certifications	CE, CB, SAA, ETL	CE, CB, SAA, ETL	CE, CB, SAA, ETL

Photometrics

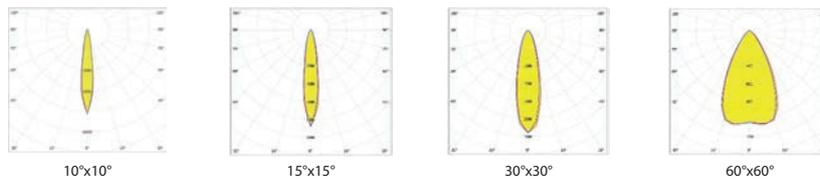

Dimensions (mm)

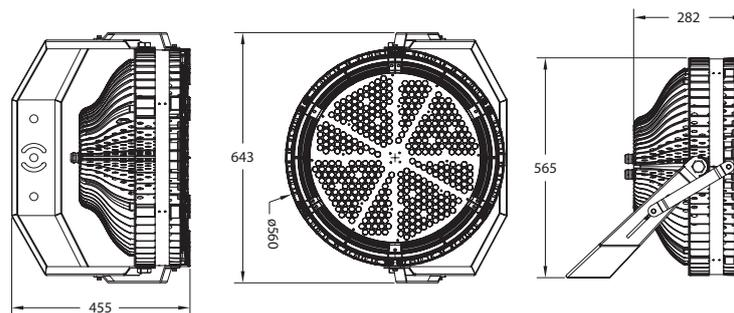

SPE-PLS-800 / SPE-PLS-1000 / SPE-PLS-1500

TITAN series

(SPE - PL)

Available from 60W to 360W IP65

Powerful and compact, the PL series is designed to provide the best illumination effect for the next generation of exterior, architectural applications. PL is a combination of proprietary thermal management technology, elegant aesthetic and precision optics for applications requiring high power concentrated beam patterns.

Designed for applications such as:

- * Building facades
- * Bridge
- * Architectural





Design Innovation



Elegant Cannon-shape product design to harmonize with the architectures
Very narrow beam (+/- 3.50) for long range projection lighting
Integrated driver for direct connection to line voltage
Simple mounting fixture for easier installation

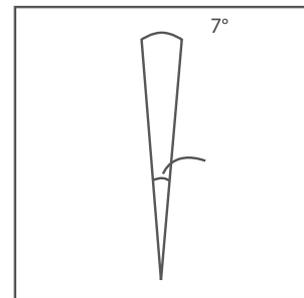

Applications

Suitable for lighting bridges, land-mark building, monuments, towers, casinos, skyscrapers, theme park, and any other outdoor high-rise buildings, etc. It is also suitable for marine and rescue lighting applications.

Remark

- This LED Projecting Light is also available in other light sources, such as Philips Lumileds Rebel ES, Luxeon Z ES, Cree XPG2, and Osram Oslon Square, etc.
- By using above LED light source, the overall system power will be reduced, while the beam angle will become more narrower accordingly. Please contact our sales team for more information.



TITAN Series SPE-PL

IP65



Parameter

Model No.	SPE-PL-060	SPE-PL-120	SPE-FL-180
Input Voltage	100-305V AC	100-305V AC	100-305V AC
LED Power	55 W	100 W	165 W
System Power	60 W	110 W	180 W
Luminous Flux	5,400 lm	9,900 lm	16,200 lm
System Efficacy	90 lm/W	90 lm/W	90 lm/W
Beam Angle	7°	7°	7°
CCT (K)	3000 / 4000 / 5000 / 6500	3000 / 4000 / 5000 / 6500	3000 / 4000 / 5000 / 6500
CRI	80	80	80
Dimmable	1-10V /DALI	1-10V /DALI	1-10V /DALI
Power Factor	> 0.90	> 0.90	> 0.90
Lifespan	50,000 H	50,000 H	50,000 H
Operating Temp.	-40°C ~ + 45°C	-40°C ~ + 45°C	-40°C ~ + 45°C
Dimension	288 x 249 x 463 mm	288 x 249 x 463 mm	345 x 335 x 479 mm
Weight (kg)	10	10,5	16
Certifications	CE	CE	CE

Photometrics

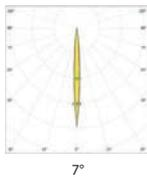

Dimensions (mm)

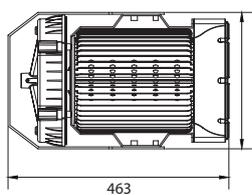

SPE-PL-060 / SPE-PL-120

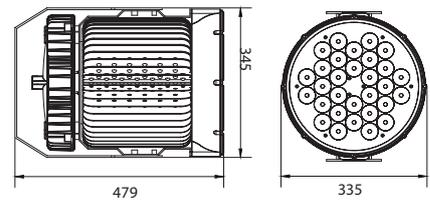

SPE-PL-180



Parameter

Model No.	SPE-PL-240	SPE-PL-300	SPE-PL-360
Input Voltage	100-305V AC	100-305V AC	100-305V AC
LED Power	200 W	260 W	300 W
System Power	220 W	280 W	330W
Luminous Flux	19,800 lm	25,200 lm	29,700 lm
System Efficacy	90 lm/W	90 lm/W	90 lm/W
Beam Angle	7°	7°	7°
CCT (K)	3000 / 4000 / 5000 / 6500	3000 / 4000 / 5000 / 6500	3000 / 4000 / 5000 / 6500
CRI	80	80	80
Dimmable	1-10V /DALI	1-10V /DALI	1-10V /DALI
Power Factor	> 0.90	> 0.90	> 0.90
Lifespan	50,000 H	50,000 H	50,000 H
Operating Temp.	-40°C ~ + 45°C	-40°C ~ + 45°C	-40°C ~ + 45°C
Dimension	345 x 335 x 479 mm	451 x 392x 578 mm	451 x 392x 578 mm
Weight (kg)	16,5	28	29
Certifications	CE	CE	CE

Photometrics

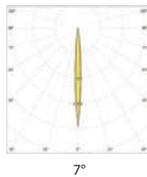

Dimensions (mm)

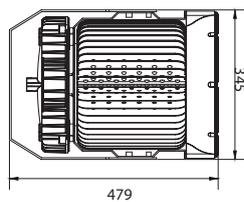

SPE-PL-240

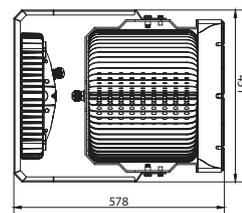
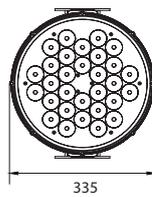

SPE-PL-300 / SPE-PL-360

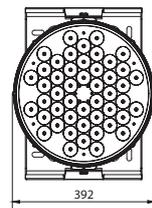

TITAN COLOR

RGB series



Available from 60W to 360W IP65





Light Source : Cree **RGBW** Series
 Supply Voltage : 90-305 VAC, 50/60 Hz
 Single LED Current : 700 mA (**R/G/B/W**)
 Control Protocol : Standard DMX512
 LED Color: **RGB**, Red, Green, Blue, White
 Beam Angle : 9°
 Lifespan: 30.000 hrs
 Operating Temp. : -25°C to +45°C

Power Supply, Controller and Decoder



Model NO.: LC-1001



Model NO.: JM-1001

Parameter

Model No.	System Power	LED Quantity	Weight	Dimension
SPE-PL-060C	60W	RGB x 12 pcs	10.0 kg	249 x 288 x 463 mm
SPE-PL-120C	120W	RGB x 18 pcs	10.5 kg	249 x 288 x 463 mm
SPE-PL-180C	180W	RGB x 30 pcs	16.0 kg	335 x 345 x 479 mm
SPE-PL-240C	240W	RGB x 36 pcs	16.5 kg	335 x 345 x 479 mm
SPE-FL-300C	300W	RGB x 48 pcs	28.5 kg	392 x 451 x 578 mm
SPE-FL-360C	360W	RGB x 54 pcs	29.0 kg	392 x 451 x 578 mm

AURORA series

(SPE - HBR / SPE - HBB)

AURORA PREMIUM
available from 70W to 200W IP65

Designed for low or high ceiling,
open space applications such as:

- * Warehouses
- * Logistic centers
- * Production workshops
- * Storage facilities
- * Commercial spaces



Best cost-performance ratio with excellent long term reliability



LED vs Metal Halide Replacement Table



The graphic compares two lighting technologies. On the left, two round, flat LED highbay lights are shown hanging from chains. In the center, the text 'LED Highbay' is followed by 'VS' and 'Metal Halide Highbay Light'. Below this, 'Energy Saving 60%' is written in large white font. To the right of the text is a single metal halide bulb. Below the comparison text is a table with two columns: LED Highbay and Metal Halide Highbay Light.

LED Highbay	Metal Halide Highbay Light
70W	- 200W
90W	250W
120W	300W - 350W
150W	400W
200W	450W - 600W

SpektraLED's round flat LED Highbay series provides the best performance and value for return-on-investment in indoor open area lighting applications, especially warehouse and production facilities. Fitted with the latest mid-power LED chips from Lumileds or Osram and powered by a high performance Meanwell driver the products come with a 5 year warranty. The whole series has a range of 70W to 200W with different variations to suit every need.

Product Key Features

- LEDs from Lumileds, Osram, together with Meanwell drivers, provide up to 5 years warranty.
- Very high lumen output at 145 lm/W efficacy
- Premium grade aluminium die cast housing and stainless steel hardware
- Unique patented thermal management design to ensure low LED junction temperature.
- Easy installation and maintenance, dust prevention, longer lifetime with high lumen maintenance.
- Type HBB: <22 UGR up to 200W with recess

Accessories

Reflector for AURORA 430 Ø

- reducing glare
- Looks like standard Highbay



AURORA Series SPE-HBR / SPE-HBB

IP65



Parameter

Model No.	SPE-HBR-070 SPE-HBB-070	SPE-HBR-090 SPE-HBB-090	SPE-HBR-120 SPE-HBB-120
Input Voltage	100-305V AC	100-305V AC	100-305V AC
LED Power	70 W	90 W	120W
System Power	77 W	99 W	132W
Luminous Flux	11,000 lm	14,200 lm	18,800 lm
System Efficacy	145 lm/W	145 lm/W	143 lm/W
Beam Angle	SPE-HBR: 120°, clear and diffuse cover / SP-HBB: 60°, clear cover		
CCT (K)	3000 / 4000 / 5000 / 6500	3000 / 4000 / 5000 / 6500	3000 / 4000 / 5000 / 6500
CRI	80	80	80
Dimmable	1-10V / DALI / PWM	1-10V / DALI / PWM	1-10V / DALI / PWM
Power Factor	> 0.90	> 0.90	> 0.90
Lifespan	100,000 H	100,000 H	100,000 H
Operating Temp.	-40°C ~ + 45°C	-40°C ~ + 45°C	-40°C ~ + 45°C
Dimension	320 x 171 mm	320 x 171 mm	HBR: 320x171 mm / HBB: 430x156 mm
Weight (kg)	3,6	3,6	HBR: 3,6 / HBB: 5,6
Certifications	CE, CB, SAA, ETL	CE, CB, SAA, ETL	CE, CB, SAA, ETL

Photometrics

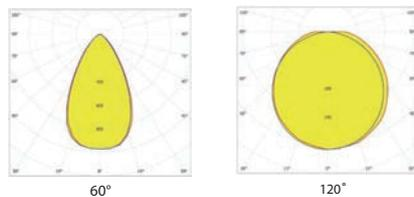

Dimensions (mm)

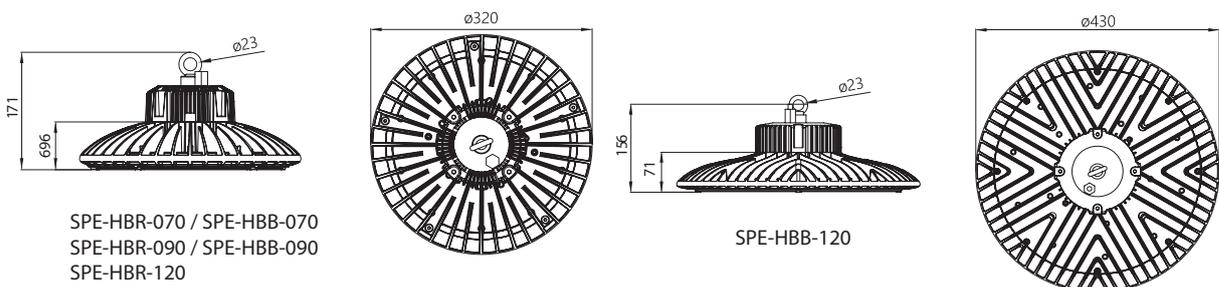



Parameter

Model No.	SPE-HBR-150 SPE-HBB-150	SPE-HBR-200 SPE-HBB-200
Input Voltage	100-305V AC	100-305V AC
LED Power	145 W	182 W
System Power	160 W	200 W
Luminous Flux	22,400 lm	28,000 lm
System Efficacy	140 lm/W	140 lm/W
Beam Angle	SPE-HBR: 120°, clear and diffuse cover / SP-HBB: 60°, clear cover	
CCT (K)	3000 / 4000 / 5000 / 6500	3000 / 4000 / 5000 / 6500
CRI	80	80
Dimmable	1-10V / DALI	1-10V / DALI
Power Factor	> 0.90	> 0.90
Lifespan	100,000 H	100,000 H
Operating Temp.	-40°C ~ + 45°C	-40°C ~ + 45°C
Dimension	430 x 156 mm	430 x 156mm
Weight (kg)	5,6	6,2
Certifications	CE, CB, SAA, ETL	CE, CB, SAA, ETL

Photometrics

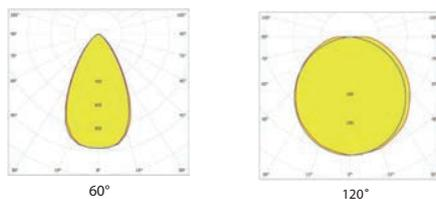

Dimensions (mm)

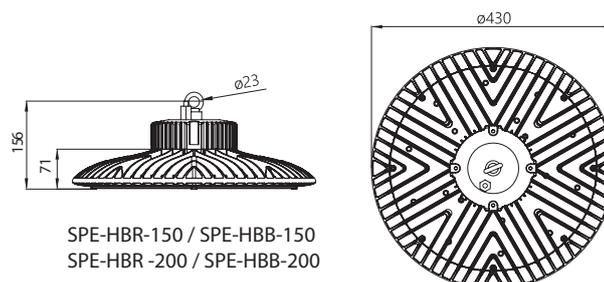

AURORA G2 series

(SPE - HBR / SPE - HBB)

AURORA G2 (SPE - HBR2 / SPE - HBB2)
available from 70W to 300W IP65

Designed for low or high ceiling,
open space applications such as:

- * Warehouses
- * Logistic centers
- * Production workshops
- * Commercial spaces



This new generation Aurora series (G2) provides the best performance and value for return-on-investment (ROI) in indoor industrial facilities lighting applications. Fitted with latest high efficiency mid-power LED chips and powered by state-of-the-art driver the products come with a 5-year warranty.

Features & Benefits

- Up to 155lm/w system efficacy
- Premium grade aluminum die cast housing and stainless steel hardware
- Best cost-performance ratio with excellent long term reliability
- High performance thermal management design ensures low LED junction temperature with high lumen maintenance
- Simple installation and maintenance
- LED Lifespan: >50,000 hours



Accessories

Reflector for AURORA G2

- reducing glare
- Looks like standard Highbay





Parameter

Model No.	SPE-HBR2-070 SPE-HBB2-070	SPE-HBR2-090 SPE-HBB2-090	SPE-HBR2-120 SPE-HBB2-120
Input Voltage	100-305V AC	100-305V AC	100-305V AC
LED Power	70 W	90 W	120W
System Power	77 W	99 W	132W
Luminous Flux	12,000 lm	15,500lm	20,800 lm
System Efficacy	155 lm/W	155 lm/W	155 lm/W
Beam Angle	SPE-HBR2: 120°, clear and diffuse cover / SP-HBB2: 60°, 90° clear cover		
CCT (K)	Standart: 4000 / 5000 Optional: 3000 / 6500		
CRI	> 80	> 80	> 80
Dimmable	1-10V / DALI / PWM	1-10V / DALI / PWM	1-10V / DALI / PWM
UGR	< 22 at 60° < 25 at 90°		
Lifespan	50,000 H	50,000 H	50,000 H
Operating Temp.	-40°C ~ + 50°C	-40°C ~ + 50°C	-40°C ~ + 50°C
Dimension	280 x 160 mm	280 x 160 mm	340 x 166 mm
Weight (kg)	2,6	2,6	3,7
Certifications	CE, CB, SAA, ETL	CE, CB, SAA, ETL	CE, CB, SAA, ETL

Photometrics

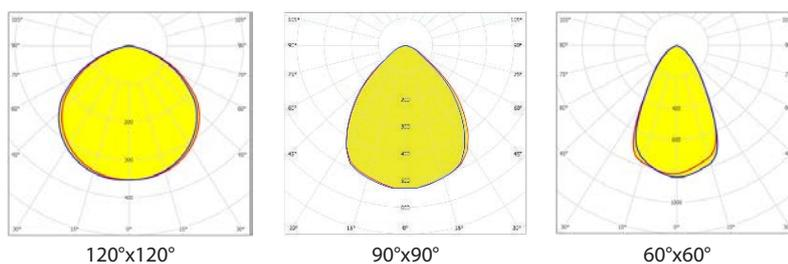

Dimensions (mm)

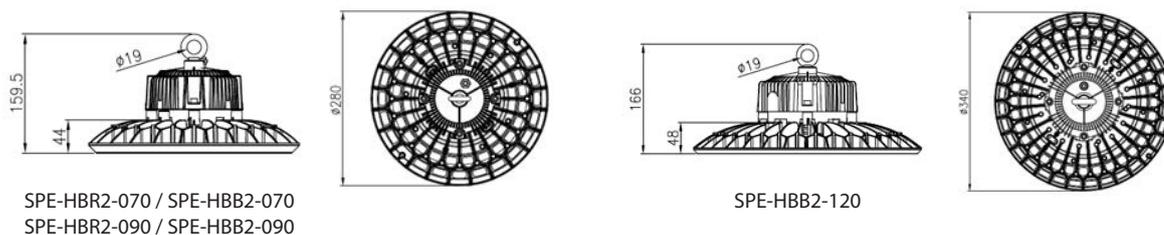

AURORA G2 Series SPE-HBR2 / SPE-HBB2

IP65



Parameter

Model No.	SPE-HBR2-150 SPE-HBB2-150	SPE-HBR2-200 SPE-HBB2-200	SPE-HBR2-300 SPE-HBB2-300
Input Voltage	100-305V AC	100-305V AC	100-305V AC
LED Power	145 W	182 W	300W
System Power	160 W	200 W	320W
Luminous Flux	25,500 lm	32,200lm	50,300 lm
System Efficacy	155 lm/W	155 lm/W	155 lm/W
Beam Angle	SPE-HBR2: 120°, clear and diffuse cover / SP-HBB2: 60°, 90° clear cover		
CCT (K)	Standart: 4000 / 5000 Optional: 3000 / 6500		
CRI	> 80	> 80	> 80
Dimmable	1-10V / DALI / PWM	1-10V / DALI / PWM	1-10V / DALI / PWM
UGR	< 22 at 60° < 25 at 90°		
Lifespan	50,000 H	50,000 H	50,000 H
Operating Temp.	-40°C ~ + 50°C	-40°C ~ + 50°C	-40°C ~ + 50°C
Dimension	340 x 166 mm	400 x 167 mm	460 x 197 mm
Weight (kg)	3,7	4,6	9,6
Certifications	CE, CB, SAA, ETL	CE, CB, SAA, ETL	CE, CB, SAA, ETL

Photometrics

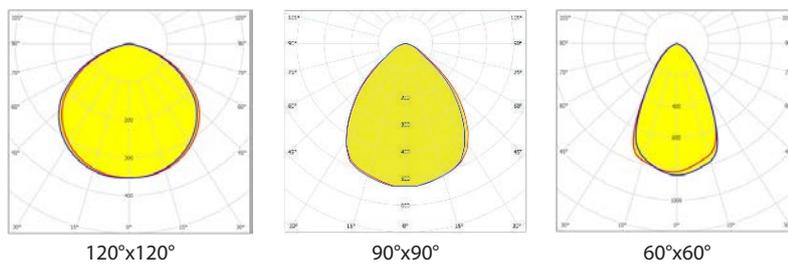

Dimensions (mm)

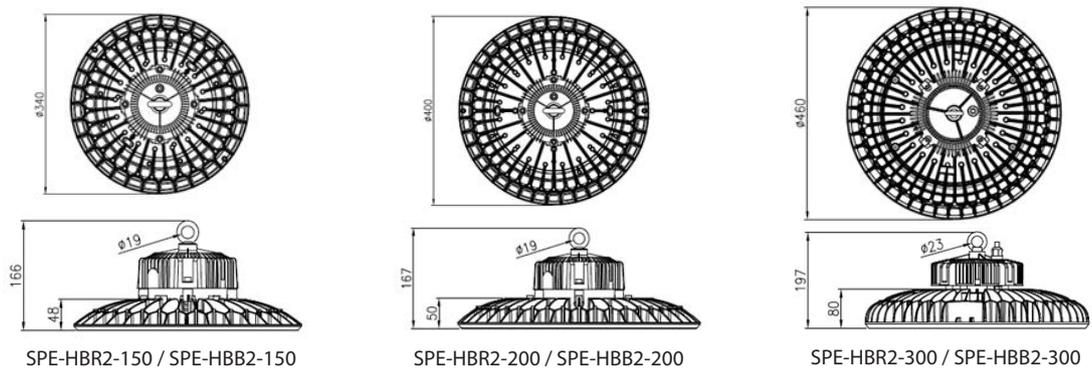

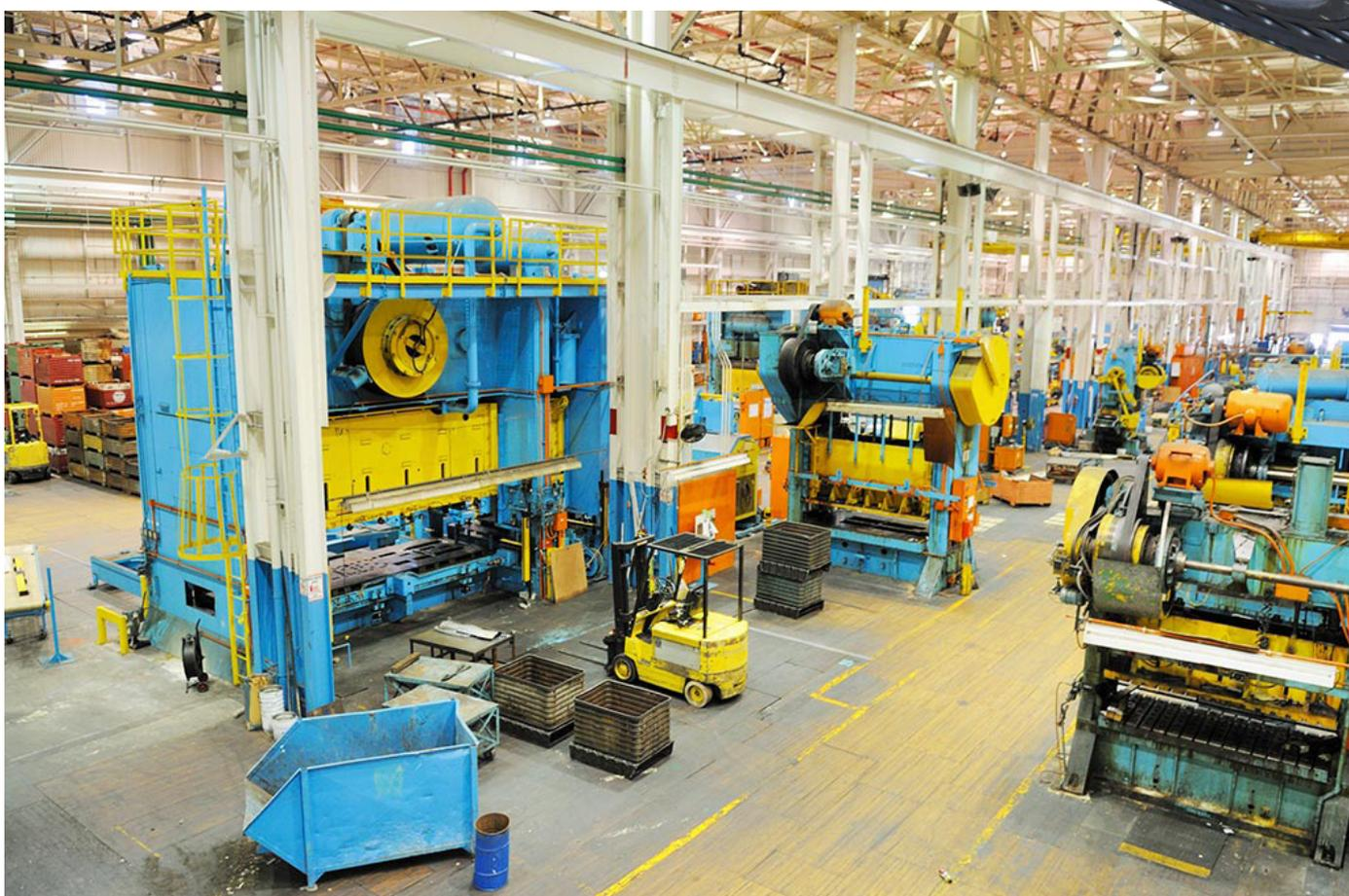

PEGASUS series

(SPE - FB)

Available from 60W to 300W

Designed for low or high applications such as:

- * Warehouse racking area
- * Production areas
- * Logistic centers
- * Storage facilities
- * Car Showerrooms
- * Supermarkets

- Available with either 1-10V or DALI dimming and compatible with all leading sensor manufacturers, Flatbays typical energy savings of over 60% compared with traditional light fixtures can be further improved with intelligent dimming.

- The powerful light output, and precision optics make the Flatbay perfectly suited for use in areas with high ceilings and ideal for sports halls needing good light and minimum glare.

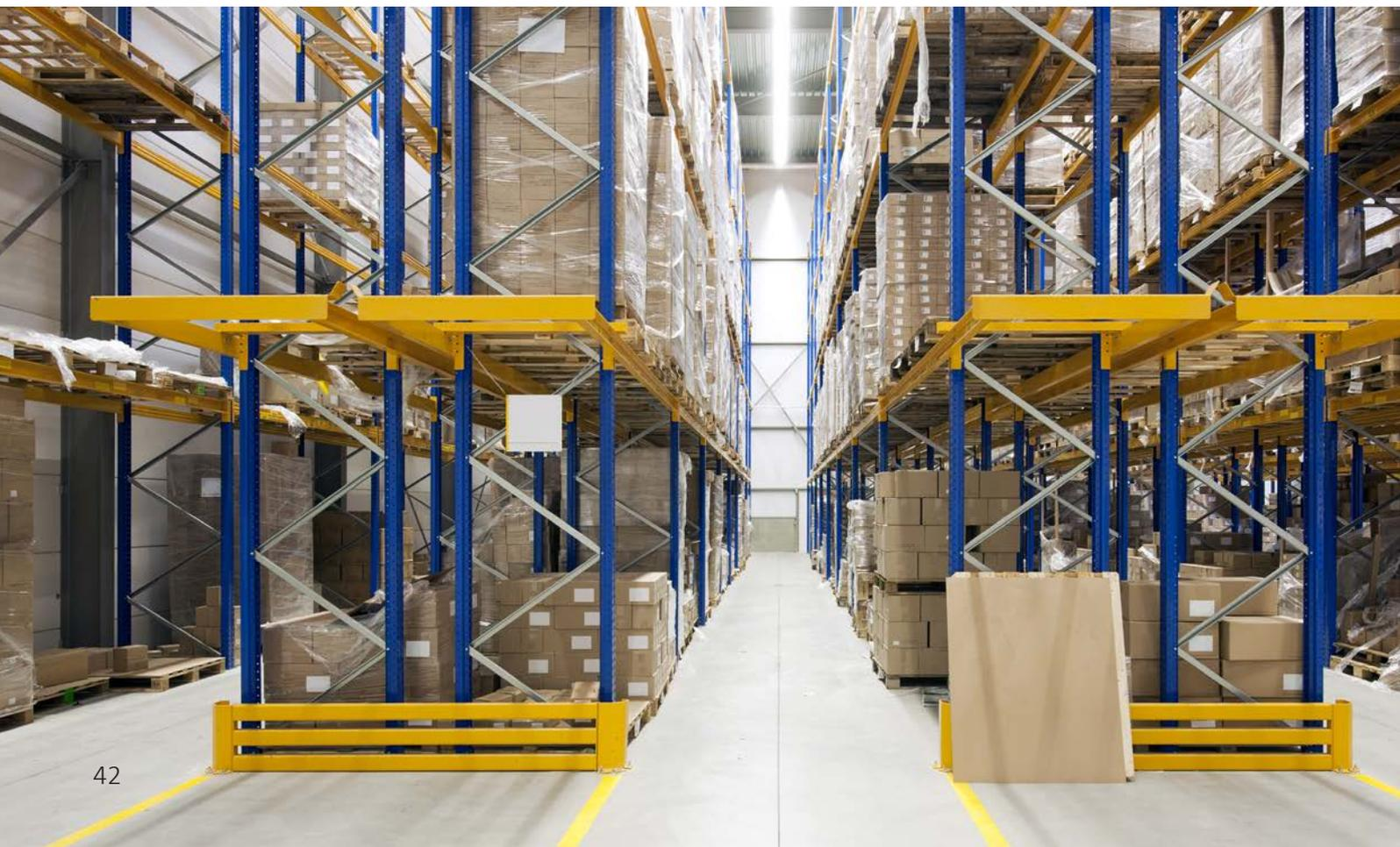



Dimensions (mm)

60w 540x158x75mm



90w 800x158x75mm



120w 1060x158x75mm



180w 1060x242x75mm

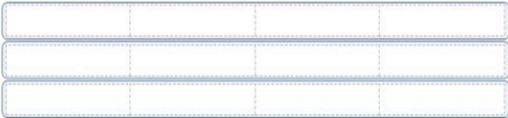

150w 1320x158x75mm



225w 1320x242x75mm



300w 1320x316x75mm



ACCESSORIES

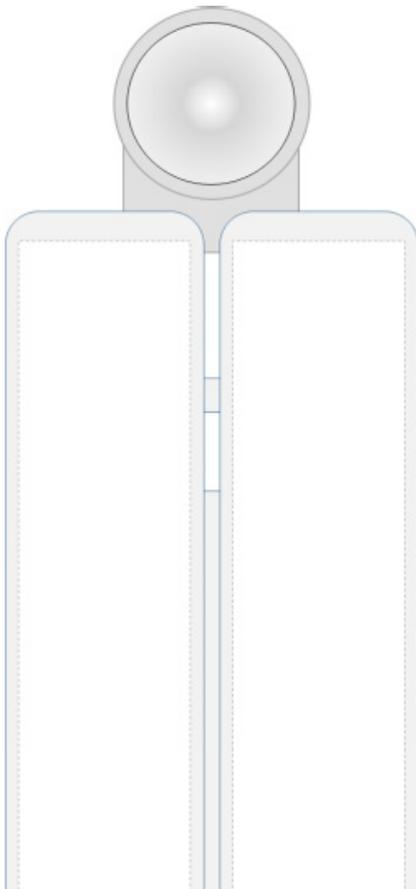

Sensor compatible

Bracket design can be custom made for different sensors

Emergency

3-hours emergency back available upon request

Mounting

Chain mounting and cord suspension kits available as standard. Surface mounting options available on request.



Chain Mounting Kit
*Chain not included

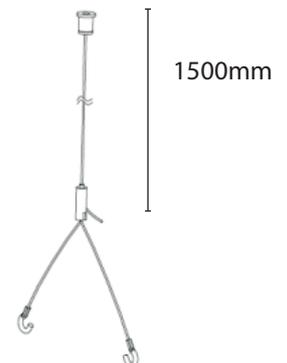

Cord Suspension Kit

PEGASUS Series SPE-FB

IP42

Parameter

Model No.	SPE-FB-060	SPE-FB-090	SPE-FB-120	SPE-FB-150
Input Voltage	100-305VAC	100-305VAC	100-305VAC	100-305VAC
LED Power	60 W	90 W	120 W	150 W
System Power	66 W	99 W	132 W	165 W
Luminous Flux	8,580 lm	12,870 lm	17,160 lm	21,450 lm
System Efficacy	130 lm/W	130 lm/W	130 lm/W	130 lm/W
Beam Angle	30°x30° / 60°x60° / 90°x90° / 120°x120° / 30°x90° / 15°x110° / 25° / 2x25°			
CCT (K)	4000 / 5000 / 6500	4000 / 5000 / 6500	4000 / 5000 / 6500	4000 / 5000 / 6500
CRI	80	80	80	80
Dimmable	1-10V / DALI	1-10V / DALI	1-10V / DALI	1-10V / DALI
Power Factor	> 0.90	> 0.90	> 0.90	> 0.90
Lifespan	50,000 H	50,000 H	50,000 H	50,000 H
Operating Temp.	-40°C ~ + 45°C	-40°C ~ + 45°C	-40°C ~ + 45°C	-40°C ~ + 45°C
Dimension	540 x 158 x 75 mm	800 x 158 x 75 mm	1060 x 158 x 75 mm	1320 x 158 x 75 mm
Weight (kg)	2,8	3,8	4,9	6,5
Certifications	CE, CB, SAA, ETL	CE, CB, SAA, ETL	CE, CB, SAA, ETL	CE, CB, SAA, ETL

Parameter

Model No.	SPE-FB-180	SPE-FB-225	SPE-FB-300
Input Voltage	100-305V AC	100-305V AC	100-305V AC
LED Power	180 W	225 W	300 W
System Power	198 W	248 W	330 W
Luminous Flux	25,740 lm	32,240 lm	42,900 lm
System Efficacy	130 lm/W	130 lm/W	130 lm/W
Beam Angle	30°x30° / 60°x60° / 90°x90° / 120°x120° / 30°x90° / 15°x110° / 25° / 2x25°		
CCT (K)	4000 / 5000 / 6500	4000 / 5000 / 6500	4000 / 5000 / 6500
CRI	80	80	80
Dimmable	1-10V / DALI / PWM	1-10V / DALI / PWM	1-10V / DALI / PWM
Power Factor	> 0.90	> 0.90	> 0.90
Lifespan	50,000 H	50,000 H	50,000 H
Operating Temp.	-40°C ~ + 45°C	-40°C ~ + 45°C	-40°C ~ + 45°C
Dimension	1060 x 242 x 75 mm	1320 x 242 x 75 mm	1320 x 316 x 75 mm
Weight (kg)	7,5	8,8	12,5
Certifications	CE, CB, SAA, ETL	CE, CB, SAA, ETL	CE, CB, SAA, ETL



Photometrics

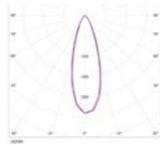

30°x30°

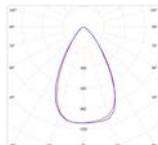

60°x60°

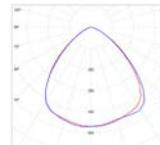

90°x90°

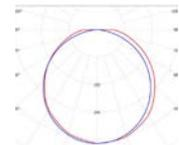

120°x120°

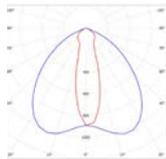

30°x90°

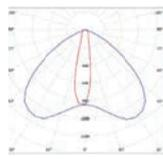

15°x110°

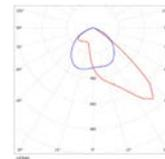

25°

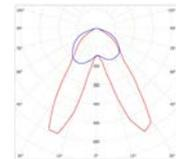

2°x25°

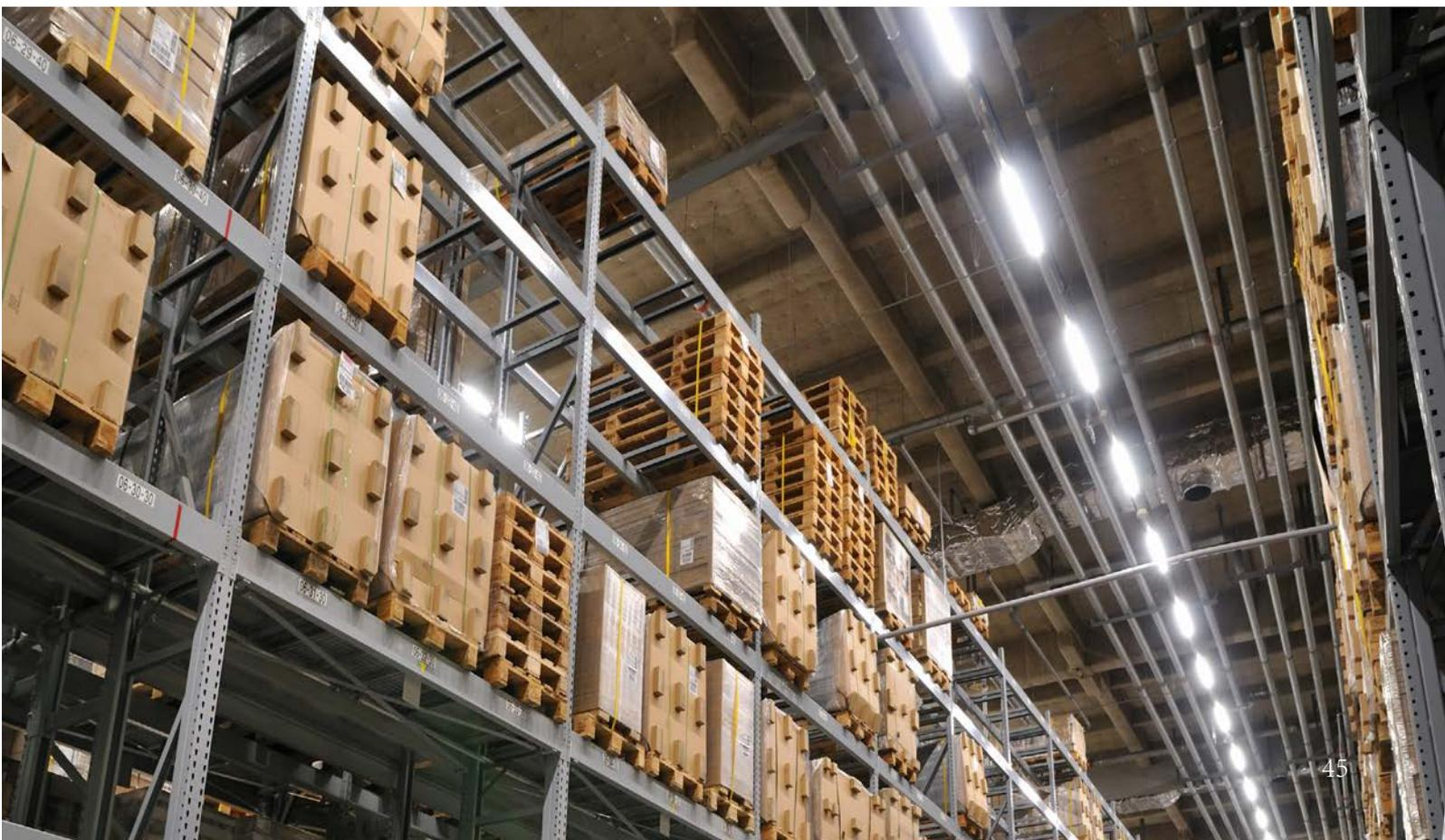

HERMES series

(SPE - LUM)

Available from 30W to 60W IP20

Designed for low or high applications such as:

- * Warehouse racking area
- * Production areas
- * Logistic centers
- * Storage facilities
- * Car Showerrooms
- * Supermarkets

LED is revolutionizing lighting and SpektraLED's next generation linear luminaire, is redefining the aesthetic and practicality of continuous lighting systems.

As industrial and commercial businesses look to grow and maximize productivity, their floor plan layouts and workspaces are constantly changing. It is therefore essential that the lighting systems used are equally flexible and adaptable.

Most existing continuous row lighting systems dictate the position of light fittings and are exclusive to only one brand of lighting fixtures. These constraints limit the functionality and flexibility of trunking based luminaires. Put simply, the user and application must adapt their requirements to the limitations of these lighting systems.

To answer this, we have created a solution that is simple to specify, fully configurable and overcomes common cost and installation barriers by putting the power of optimization and performance in the hands of the user.

SpektraLED's LED Continuous Lighting System

also called Trunking System ,is engineered to deliver unparalleled lighting performance and bring an elegant, understated design element to a work or retail space. The system can be tailored to application whilst remaining future-proof, cost-effective and easy to deploy in both retrofit projects and new builds.



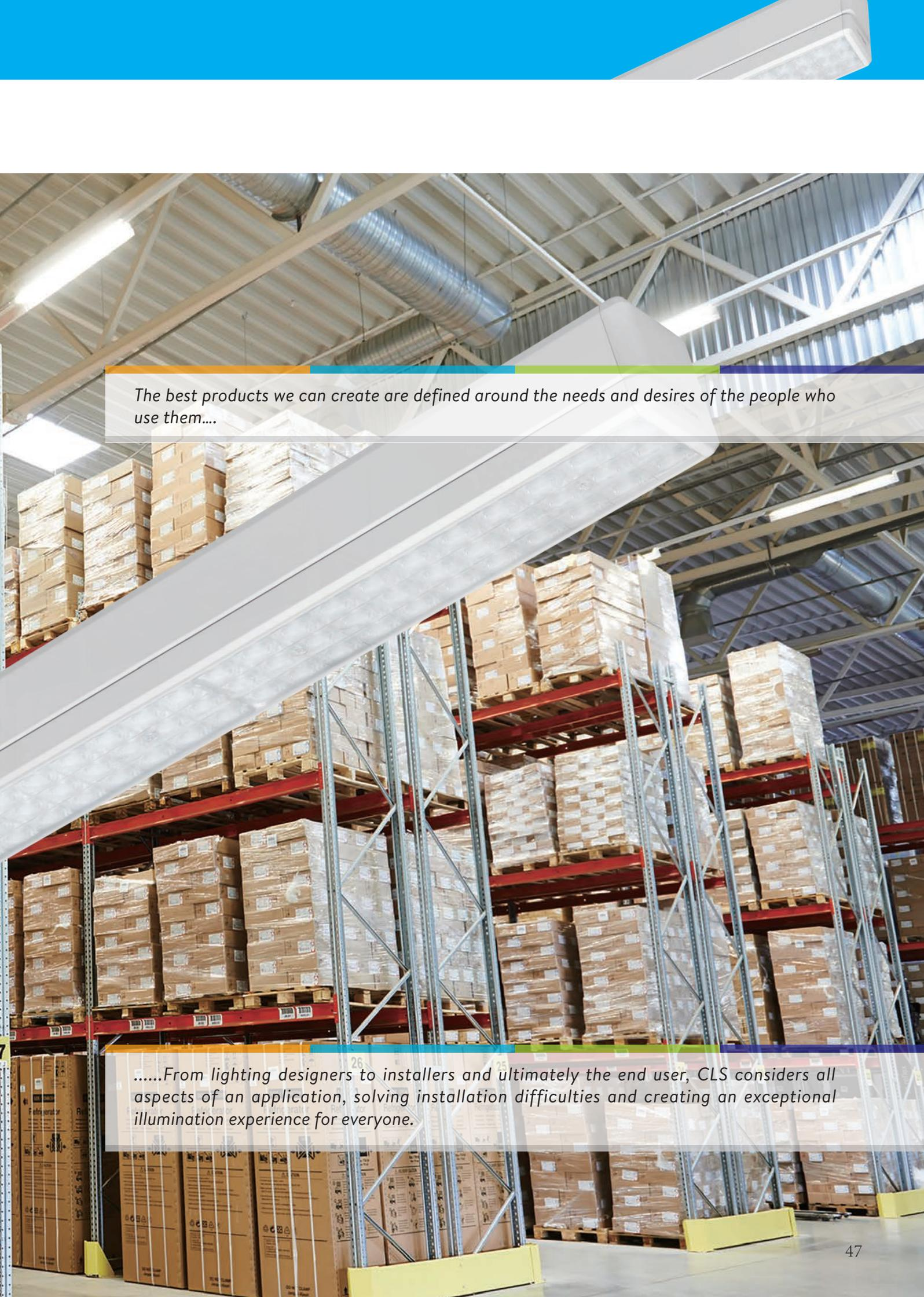

The best products we can create are defined around the needs and desires of the people who use them....

.....From lighting designers to installers and ultimately the end user, CLS considers all aspects of an application, solving installation difficulties and creating an exceptional illumination experience for everyone.

Trunking

The trunking profile invisibly connects into seamless rows of any desired length. The proprietary electrical rail enables installers to fit the luminaires exactly where they are needed, allowing for only the mechanical and electrical connection between trunking lengths. This creates full flexibility to optimize the lighting layout for an ever changing workspace.

Aluminium housing

Double power coating available in:

White

Black

Clickplay power line

Multiple circuit options

5 Pole (5 x 2.5mm²) : L1/L2/L3/N/ \perp

Separately switchable circuits for extremely easy light control in triple circuit.

7 Pole (7 x 2.5mm²) : L1/L2/L3/N/ \perp / D+/D-

Additional 2 pole for 0-10v / DALI connection to customised Intelligent lighting management systems.

11 Pole /L2e/N1e/N2e

Additional 4 poles for two independent emergency lighting circuits.

Unique locking design that enables perfect long length alignment

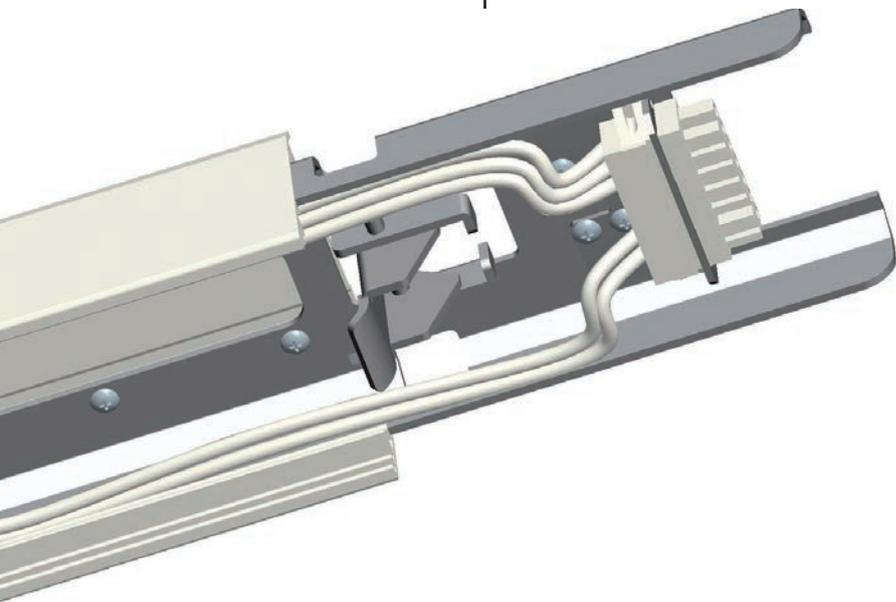

Seamless connection



Dimensions

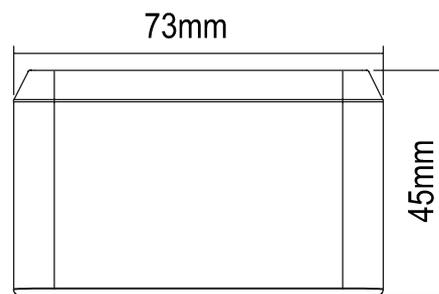

Trunking lengths

Identical lengths to multiples of CLS LED enables simple project design and install

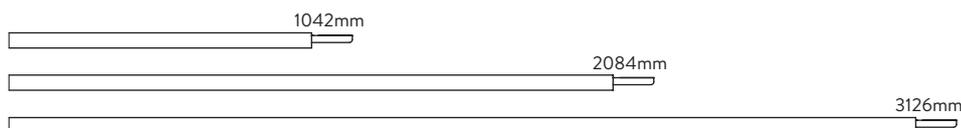

Individual trunking units

Designed for CLS Single.



Blank end trunking

Can be cut to any length at the end of the continuous row system.



HERMES Series SPE-LUM

IP20



Parameter

Model No.	SPE-LUM-30	SPE-LUM-040	SPE-LUM-060
Input Voltage	100-305V AC	100-305V AC	100-305V AC
LED Power	27 W	36 W	55 W
System Power	30 W	40 W	60 W
Luminous Flux	4,200 lm	5,600 lm	7,800 lm
System Efficacy	140 lm/W	140 lm/W	140 lm/W
Beam Angle	30°x30° / 60°x60° / 90°x90° / 120°x120° / 30°x90° / 15°x110° / 25° / 2x25°		
CCT (K)	3000K / 4000 / 5000 / 6500	3000K / 4000 / 5000 / 6500	3000 / 4000 / 5000 / 6500
CRI	80	80	80
Dimmable	1-10V / DALI	1-10V / DALI	1-10V / DALI
Power Factor	> 0.95	> 0.95	> 0.95
Lifespan	50,000 H	50,000 H	50,000 H
Operating Temp.	-40°C ~ + 40°C	-40°C ~ + 40°C	-40°C ~ + 40°C
Weight (kg)	10	10	10
Certifications	CE	CE	CE

Photometrics

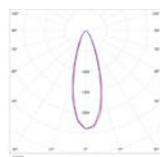

30° x 30°

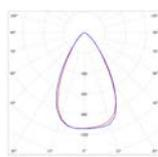

60° x 60°

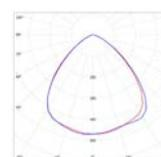

90° x 90°

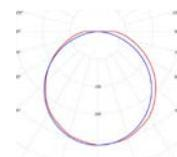

120° x 120°

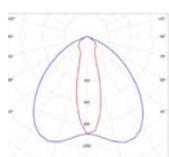

30° x 90°

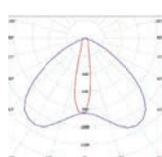

15° x 110°

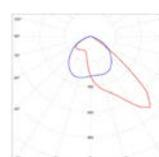

25°

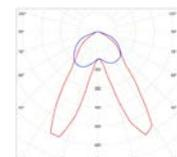

2 x 25°

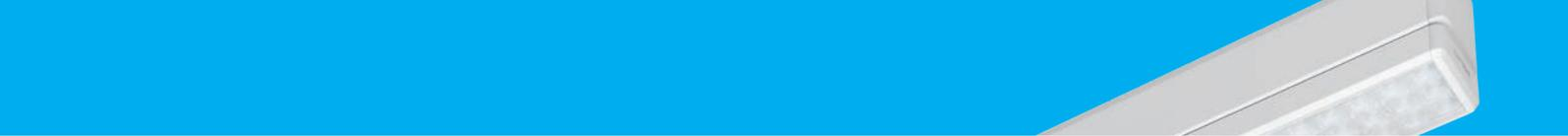

Dimensions (mm)

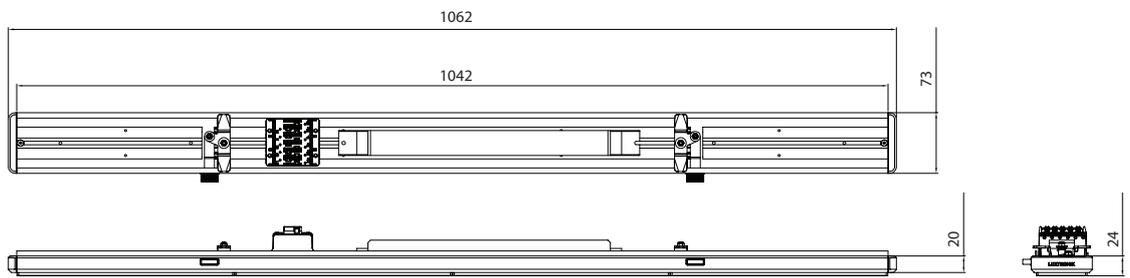

Installation

Light weight yet durable materials allow for rapid, single person connection, drastically reducing the installation and handling costs when upgrading your lighting.

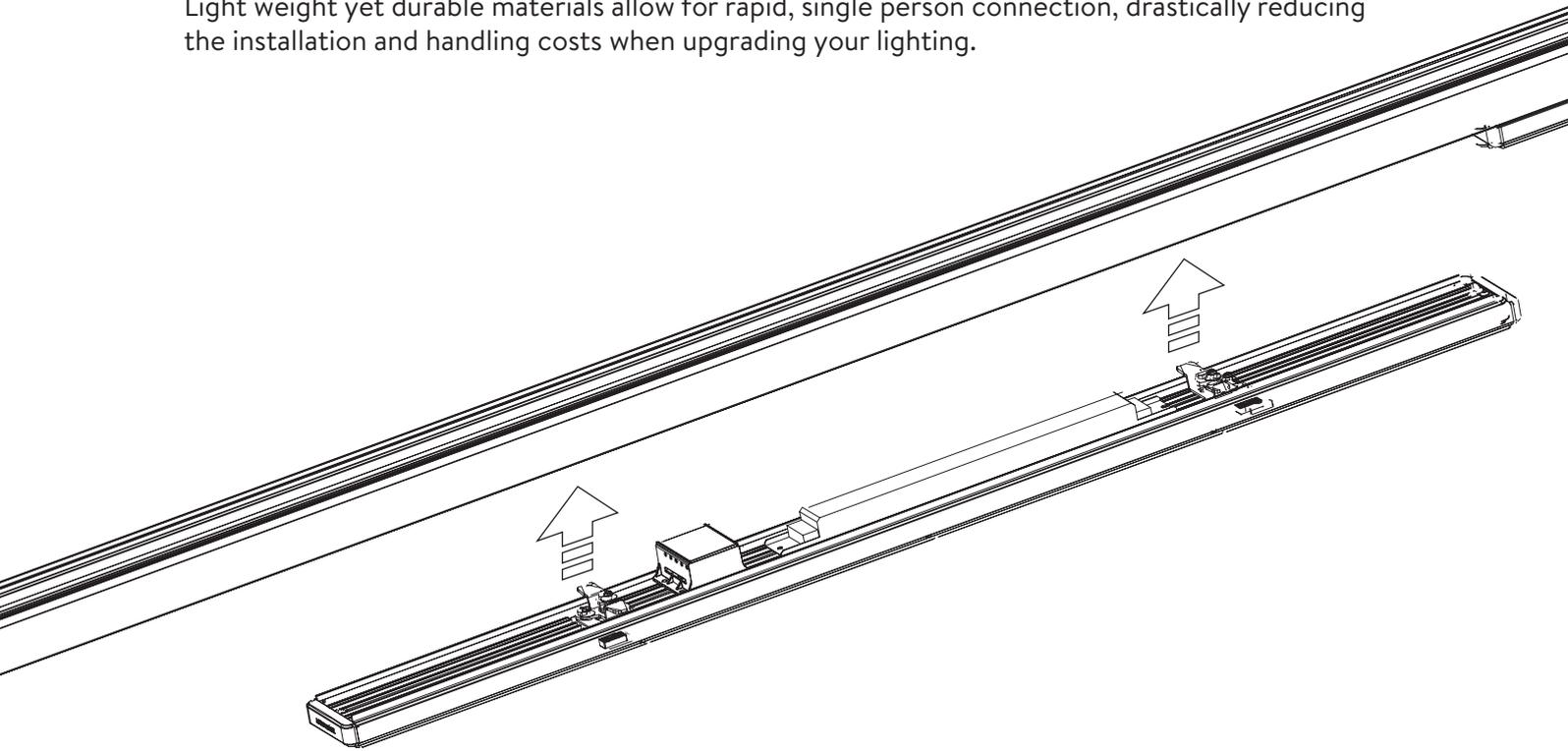

Overall Dimensions

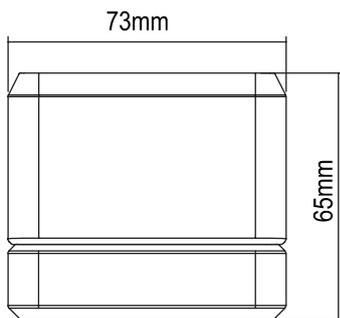

Electrical Feed



Fixing Options

Suspension and surface fixing kits available.



Surface Mounted



Chain Suspension



Wire Suspension



Wall Mounted



Reverse polarity resistant

Mechanical design prevents inadvertent polarity reversal during assembly.
Colour coding makes it simple to install correctly

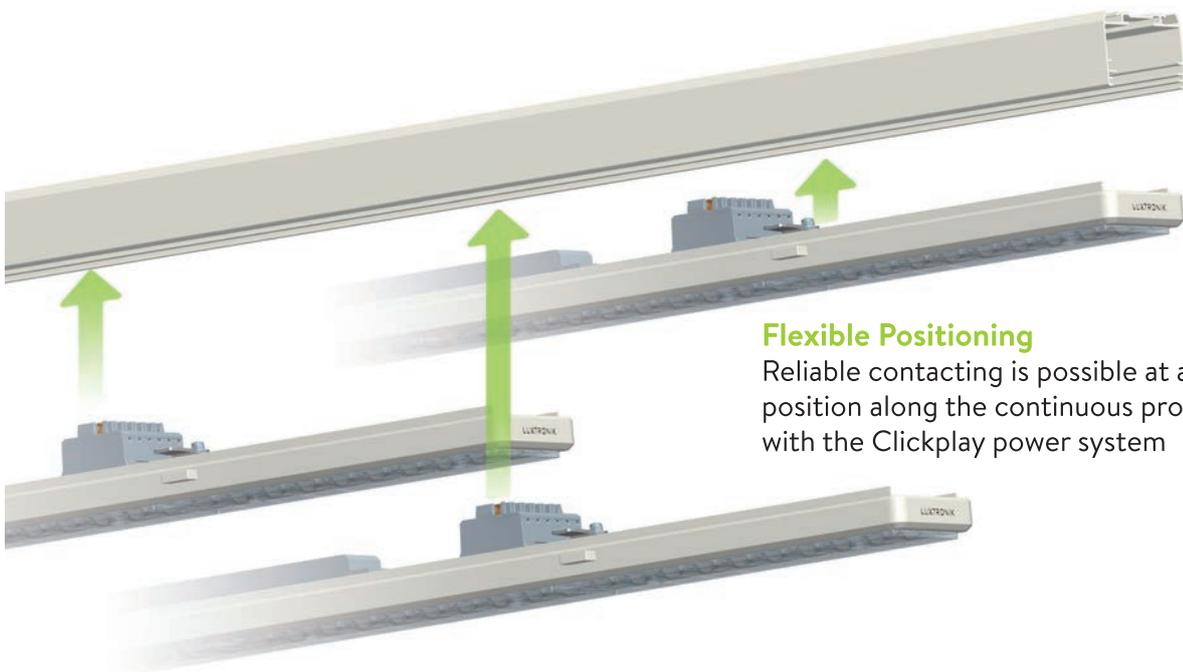

Flexible Positioning

Reliable contacting is possible at any position along the continuous profile with the Clickplay power system

Open Source Interface

CLS Interface offers the ability to add 3rd party fixtures with various beam patterns, colors and aesthetics, allowing lighting designers to solve many types of lighting challenges from small office interiors to large warehouse and industrial spaces.



Nodes

Multiple node options allow lighting designers to configure any type of installation

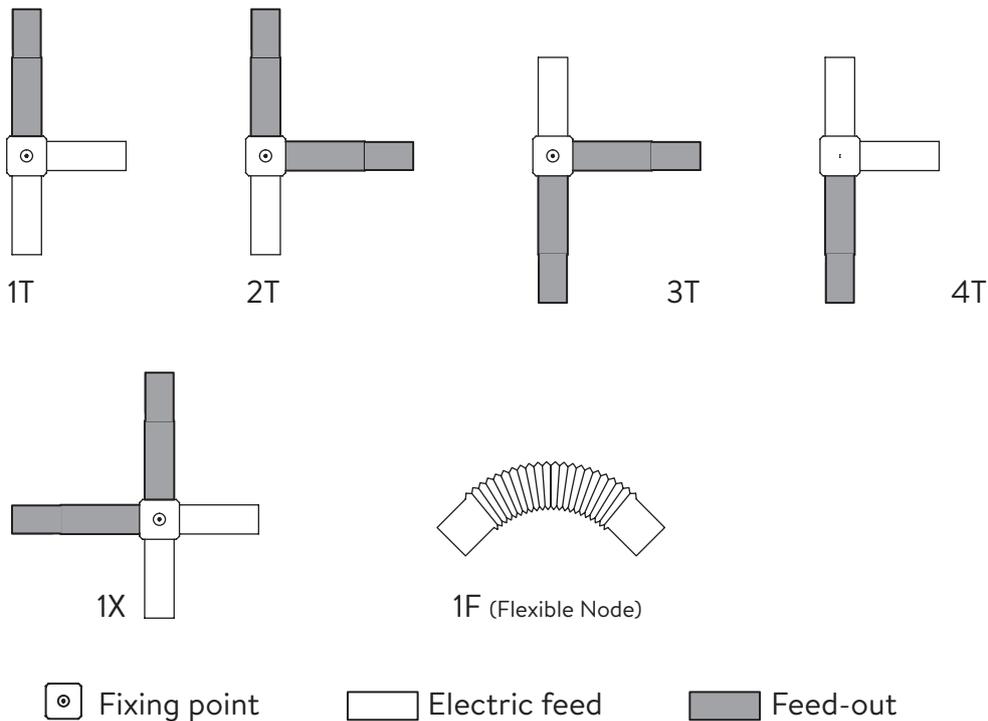

Single unit

Where it is not possible or necessary to install trunking, CLS LED Single provides the perfect alternative as a standalone luminaire with the same perfect levels of lighting quality, performance and efficiency.



Sensor adaptable

Motion and daylight sensor options allow the system to maximize energy savings.

- **PIR** sensors are recommended for warehouse lighting where high vibration can cause disturbance with other solutions.
- **Microwave**, with its high sensitivity is perfect for retail spaces and storage facilities



Length of light line (meter)	Max Luminares (1042mm)	Trunking sections			Min Mounting brackets	Suggested AC Electrical feeds
		1042mm	2084mm	3126mm		
1.0	1	1			2	1
2.1	2		1		2	1
3.1	3			1	2	1
4.2	4		2		2	1
5.2	5		1	1	3	1
6.3	6			2	3	1
7.3	7	1		2	4	1
8.3	8		1	2	4	1
9.4	9			3	5	1
10.4	10	1		3	5	1
11.5	11		1	3	6	1
12.5	12			4	6	1
13.5	13	1		4	7	1
14.6	14		1	4	7	1
15.6	15			5	8	1
16.7	16	1		5	8	1
17.7	17		1	5	9	1
18.8	18			6	9	1
19.8	19	1		6	10	1
20.8	20		1	6	10	1

PANDORA series

(SPE - M)

AIRFLOW

Discrete multi-channels create a flow through cooling effect that allows air to circulate around the light engine core, maintaining a low LED junction temperature and optimal performance.

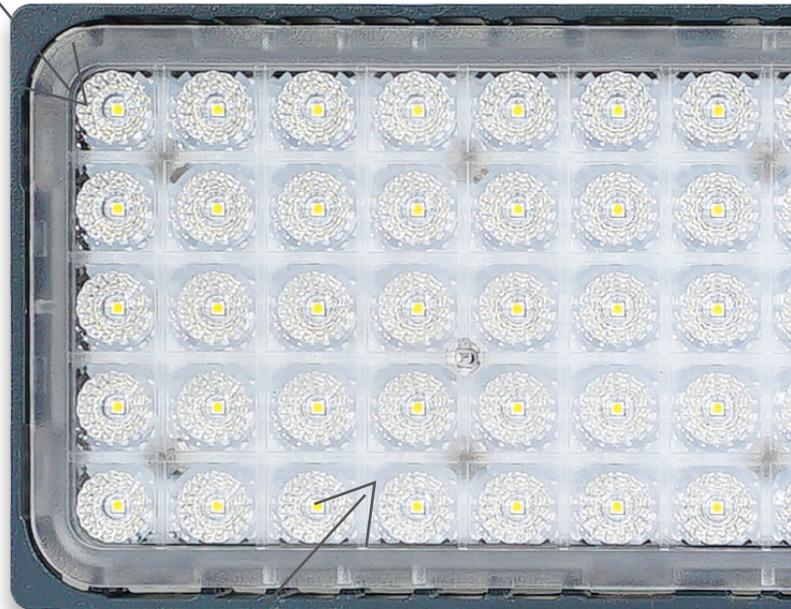

OPTICS

A variety of click in, easy fit optics, customize the light beam to deliver the perfect performance.

PERFORMANCE

130lm/w Designed to meet and exceed industry performance standards



CONNECTIVITY

Removing the need for external cabling by invisibly connecting the light engines and power supply for fast, simplified electrical connection.



FINISH

Zinc galvanized and powder coated for durable weather resistance in tough environments

WATERPROOF

Unique silicone based waterproof technology enables instant IP65 rating for the light engines



Your Challenges

Industrial and area lighting require a large variety of light beam patterns to best illuminate the many diverse applications and environments. Quick delivery is often crucial in winning lighting projects but attempting to stock such a wide range of industrial luminaires has virtually been impossible to do so without a large upfront investment. Until now companies and their clients have had to suffer long delays in delivery or make rush shipments in order to meet project deadlines, severely cutting in to their bottom line.

How We Solve Them

The brand new OEM Modular LED System (MFL) is a fusion of exciting new technologies that will give our partners the flexibility to customize optics and build a variety of luminaires on demand. The simple to assemble, scalable system provides key advantages in fast project customization, performance and delivery, helping your business grow and succeed in the Industrial lighting market.

PANDORA Modular Family

- Flood Light
- Highbay
- Car Park Light
- Canopy Light

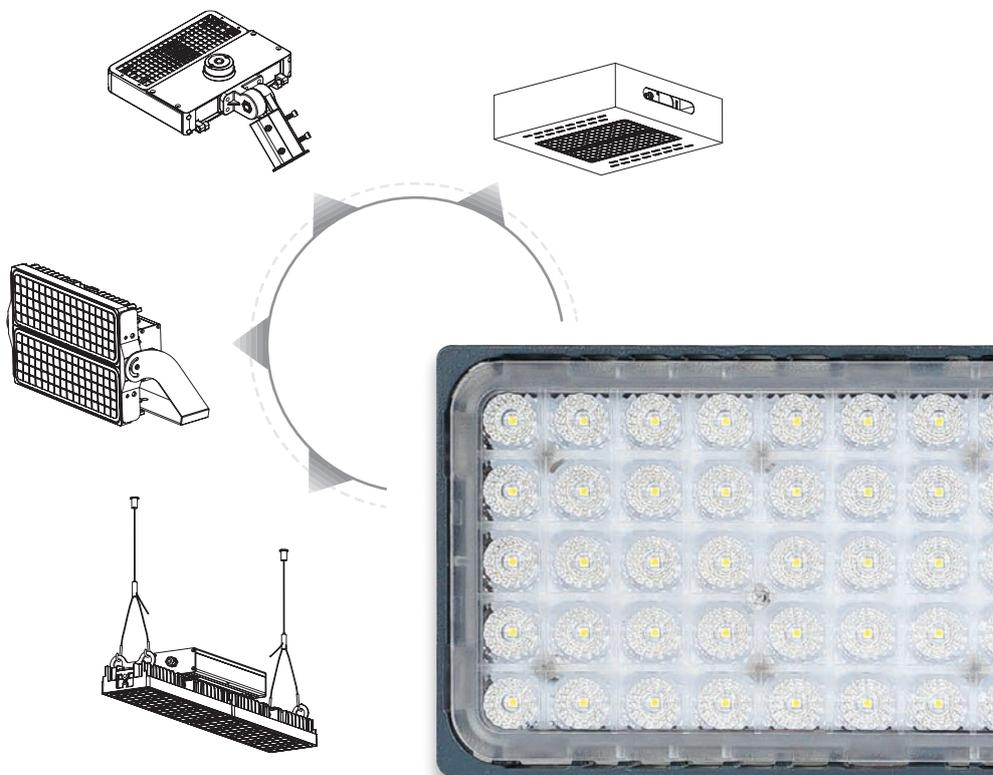



Accessories

Flood Light Series SPE-MCP

Sensor compatible
NEMA socket available request in 5 or 7 pin.



Mounting

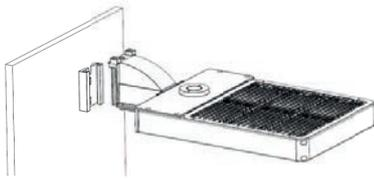

Wall Mounted

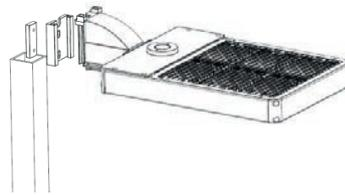

Pole Mounted

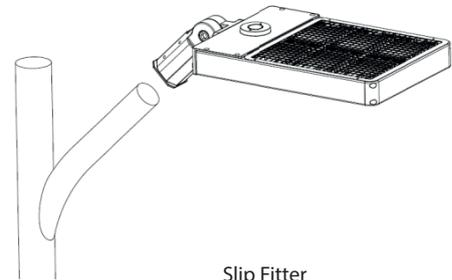

Slip Fitter

Highbay Series SPE-MHB

Sensor compatible
Bracket design can be custom made for different motion or daylight sensors (ordered separately)



Mounting

Chain mounting and cord suspension kits available as standard. Surface mounting options available on request.



150mm

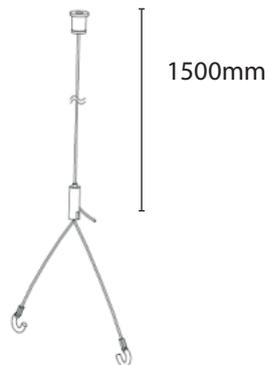

1500mm

Chain Mounting Kit

*Chain not included

Cord Suspension Kit

Emergency

3-hour emergency back-up available on request

PANDORA Flood Light Series SPE-MFL

IP65 Available from 50W to 400W

Flood Light is ideal for:

- * Building facades
- * Area lighting
- * Signage & Billboards
- * Depots
- * Heavy industrial and wet locations

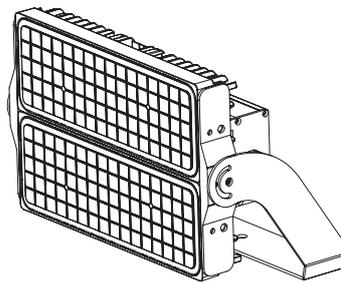

Parameter

Model No.	SPE-MFL-050	SPE-MFL-075	SPE-MFL-100	SPE-MFL-150L
Input Voltage	100-305VAC	100-305VAC	100-305VAC	100-305VAC
LED Power	50 W	75 W	100 W	150 W
System Power	55 W	80 W	110 W	165 W
Luminous Flux	7,100 lm	9,600 lm	14,300 lm	19,000 lm
System Efficacy	130 lm/W	130 lm/W	130 lm/W	130 lm/W
Beam Angle	30°x30° / 60°x60° / 90°x90° / 30°x100° / 50°x140° / 40°x140° / 30°x140° / 140°x140°			
CCT (K)	4000 / 5000 / 6500	4000 / 5000 / 6500	4000 / 5000 / 6500	4000 / 5000 / 6500
CRI	80	80	80	80
Dimmable	1-10V / DALI	1-10V / DALI	1-10V / DALI	1-10V / DALI
Power Factor	> 0.90	> 0.90	> 0.90	> 0.90
Lifespan	50,000 H	50,000 H	50,000 H	50,000 H
Operating Temp.	-40°C ~ + 40°C	-40°C ~ + 40°C	-40°C ~ + 40°C	-40°C ~ + 40°C
Module Quantity	1	1	2	2
Weight (kg)	-	-	-	-
Certifications	CE, CB, SAA, ETL	CE, CB, SAA, ETL	CE, CB, SAA, ETL	CE, CB, SAA, ETL

Photometrics

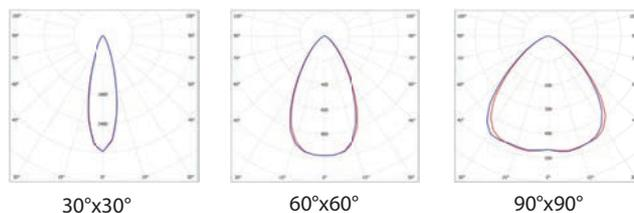

Dimensions (mm)

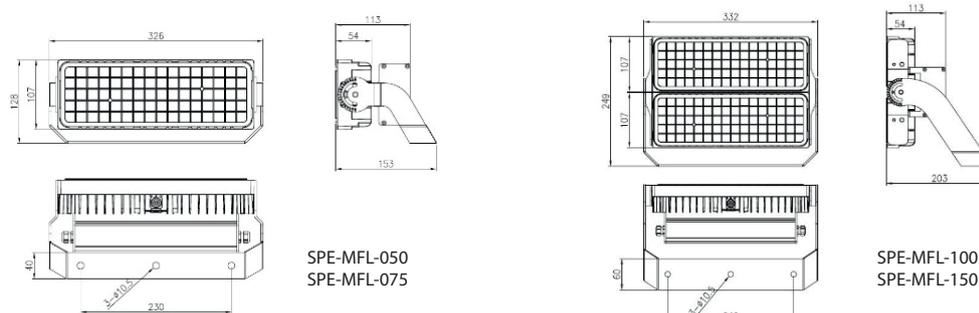

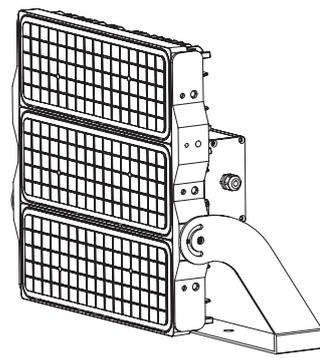

Parameter

Model No.	SPE-MFL-150H	SPE-MFL-200	SPE-MFL-300	SPE-MFL-400
Input Voltage	100-305VAC	100-305VAC	100-305VAC	100-305VAC
LED Power	150 W	200 W	300 W	400 W
System Power	165 W	220 W	330 W	440 W
Luminous Flux	21,400 lm	26,800 lm	39,600 lm	57,000 lm
System Efficacy	130 lm/W	130 lm/W	130 lm/W	130 lm/W
Beam Angle	30°x30° / 60°x60° / 90°x90° / 30°x100° / 50°x140° / 40°x140° / 30°x140° / 140°x140°			
CCT (K)	4000 / 5000 / 6500	4000 / 5000 / 6500	4000 / 5000 / 6500	4000 / 5000 / 6500
CRI	80	80	80	80
Dimmable	1-10V / DALI	1-10V / DALI	1-10V / DALI	1-10V / DALI
Power Factor	> 0.90	> 0.90	> 0.90	> 0.90
Lifespan	50,000 H	50,000 H	50,000 H	50,000 H
Operating Temp.	-40°C ~ + 40°C	-40°C ~ + 40°C	-40°C ~ + 40°C	-40°C ~ + 40°C
Module Quantity	3	3	4	6
Weight (kg)	-	-	-	-
Certifications	CE, CB, SAA, ETL	CE, CB, SAA, ETL	CE, CB, SAA, ETL	CE, CB, SAA, ETL

Photometrics

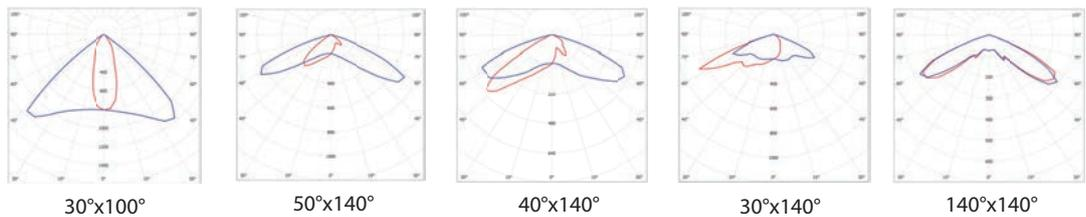

Dimensions (mm)

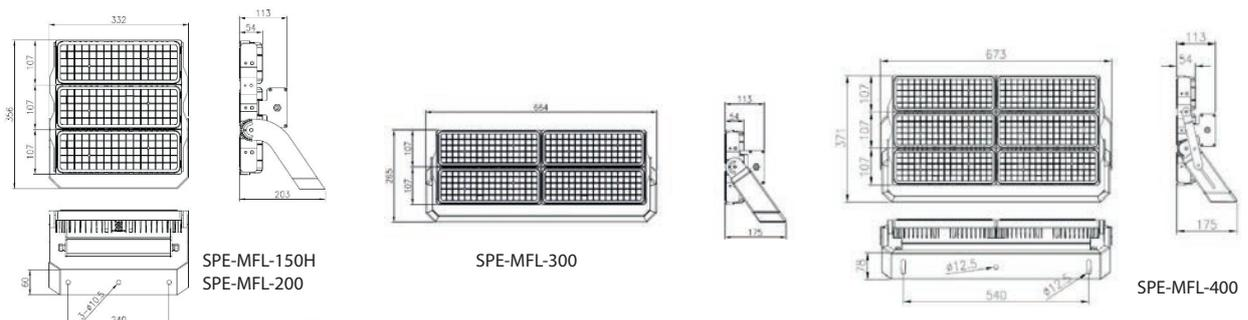

PANDORA Flood Light Series SPE-MCP

IP65 Available from 50W to 300W

Flood Light is ideal for:

- * Facility lighting
- * Parking lots
- * Street lighting

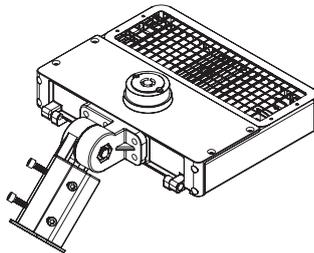

Parameter

Model No.	SPE-MCP-050	SPE-MCP-075	SPE-MCP-100	SPE-MCP-150L
Input Voltage	100-305VAC	100-305VAC	100-305VAC	100-305VAC
LED Power	50 W	75 W	100 W	150 W
System Power	55 W	80 W	110 W	165 W
Luminous Flux	7,100 lm	9,600 lm	14,300 lm	19,000 lm
System Efficacy	130 lm/W	130 lm/W	130 lm/W	130 lm/W
Beam Angle	30°x30° / 60°x60° / 90°x90° / 30°x100° / 50°x140° / 40°x140° / 30°x140° / 140°x140°			
CCT (K)	4000 / 5000 / 6500	4000 / 5000 / 6500	4000 / 5000 / 6500	4000 / 5000 / 6500
CRI	80	80	80	80
Dimmable	1-10V / DALI	1-10V / DALI	1-10V / DALI	1-10V / DALI
Power Factor	> 0.90	> 0.90	> 0.90	> 0.90
Lifespan	50,000 H	50,000 H	50,000 H	50,000 H
Operating Temp.	-40°C ~ + 40°C	-40°C ~ + 40°C	-40°C ~ + 40°C	-40°C ~ + 40°C
Module Quantity	1	1	2	2
Weight (kg)	-	-	-	-
Certifications	CE, CB, SAA, ETL	CE, CB, SAA, ETL	CE, CB, SAA, ETL	CE, CB, SAA, ETL

Photometrics

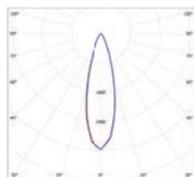

30°x30°

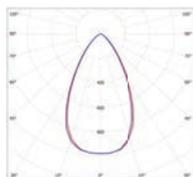

60°x60°

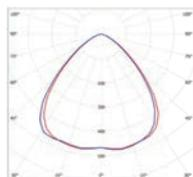

90°x90°

Dimensions (mm)

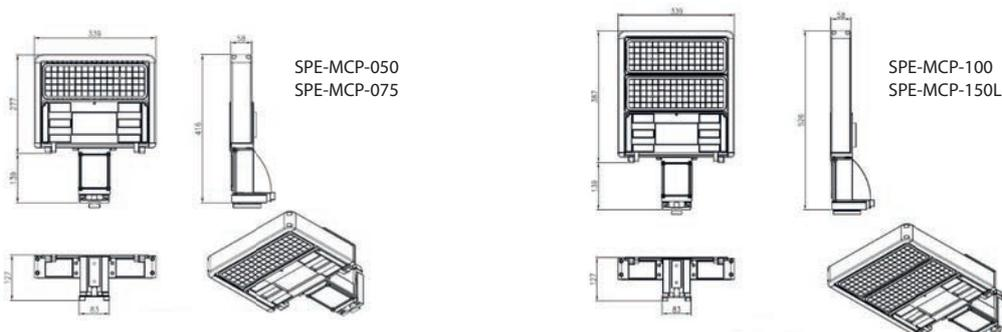

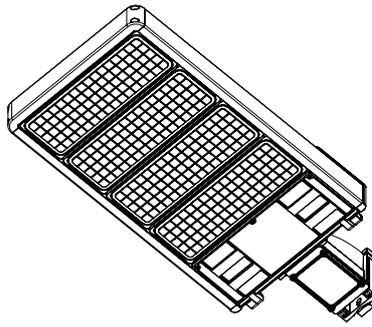

Parameter

Model No.	SPE-MCP-150H	SPE-MCP-200	SPE-MCP-300
Input Voltage	100-305VAC	100-305VAC	100-305VAC
LED Power	150 W	200 W	300 W
System Power	165 W	220 W	330 W
Luminous Flux	21,400 lm	26,800 lm	39,600 lm
System Efficacy	130 lm/W	130 lm/W	130 lm/W
Beam Angle	30°x30° / 60°x60° / 90°x90° / 30°x100° / 50°x140° / 40°x140° / 30°x140° / 140°x140°		
CCT (K)	4000 / 5000 / 6500	4000 / 5000 / 6500	4000 / 5000 / 6500
CRI	80	80	80
Dimmable	1-10V / DALI	1-10V / DALI	1-10V / DALI
Power Factor	> 0.90	> 0.90	> 0.90
Lifespan	50,000 H	50,000 H	50,000 H
Operating Temp.	-40°C ~ + 40°C	-40°C ~ + 40°C	-40°C ~ + 40°C
Module Quantity	3	3	4
Weight (kg)	-	-	-
Certifications	CE, CB, SAA, ETL	CE, CB, SAA, ETL	CE, CB, SAA, ETL

Photometrics

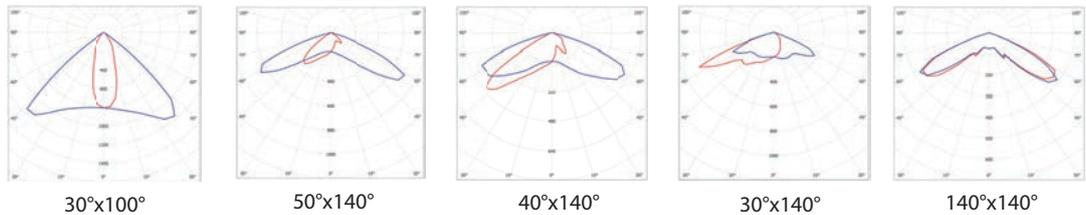

Dimensions (mm)

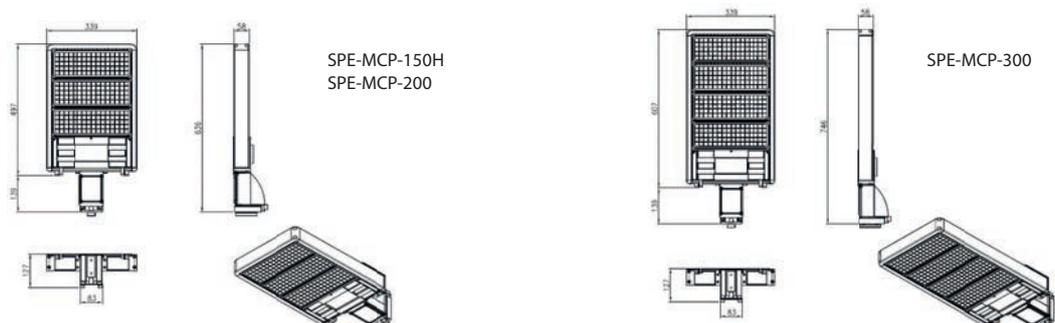

PANDORA Highbay Series SPE-MHB

IP65 Available from 50W to 400W

Flood Light is ideal for:

- * Cold Storage facilities
- * Wet Location areas
- * Warehouses
- * Logistic centers
- * Production workshops

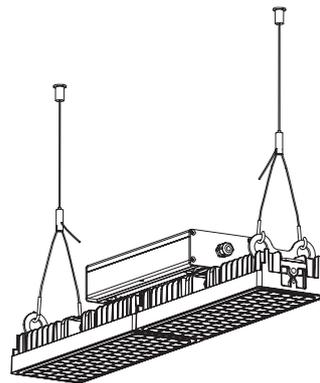

Parameter

Model No.	SPE-MHB-050	SPE-MHB-075	SPE-MHB-100	SPE-MFL-150L
Input Voltage	100-305VAC	100-305VAC	100-305VAC	100-305VAC
LED Power	50 W	75 W	100 W	150 W
System Power	55 W	80 W	110 W	165 W
Luminous Flux	7,100 lm	9,600 lm	14,300 lm	19,000 lm
System Efficacy	130 lm/W	130 lm/W	130 lm/W	130 lm/W
Beam Angle	30°x30° / 60°x60° / 90°x90° / 30°x100° / 50°x140° / 40°x140° / 30°x140° / 140°x140°			
CCT (K)	4000 / 5000 / 6500	4000 / 5000 / 6500	4000 / 5000 / 6500	4000 / 5000 / 6500
CRI	80	80	80	80
Dimmable	1-10V / DALI	1-10V / DALI	1-10V / DALI	1-10V / DALI
Power Factor	> 0.90	> 0.90	> 0.90	> 0.90
Lifespan	50,000 H	50,000 H	50,000 H	50,000 H
Operating Temp.	-40°C ~ + 40°C	-40°C ~ + 40°C	-40°C ~ + 40°C	-40°C ~ + 40°C
Module Quantity	1	1	2	2
Weight (kg)	-	-	-	-
Certifications	CE, CB, SAA, ETL	CE, CB, SAA, ETL	CE, CB, SAA, ETL	CE, CB, SAA, ETL

Photometrics

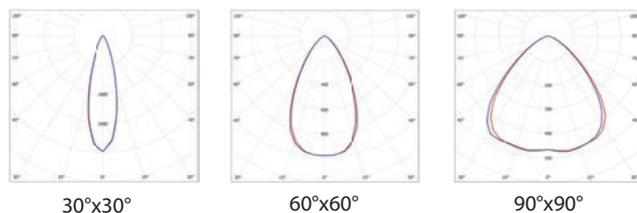

Dimensions (mm)

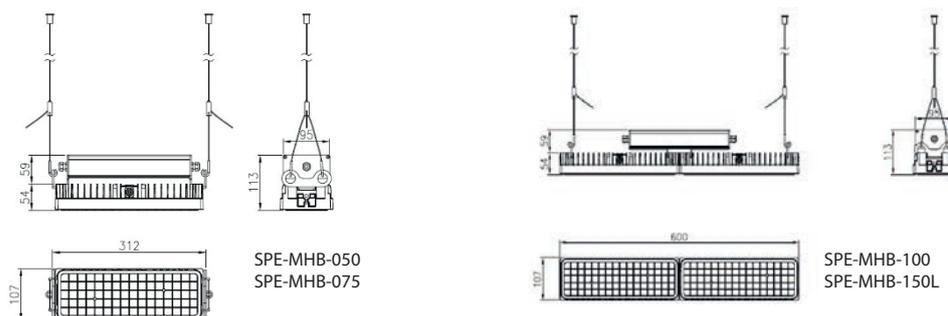

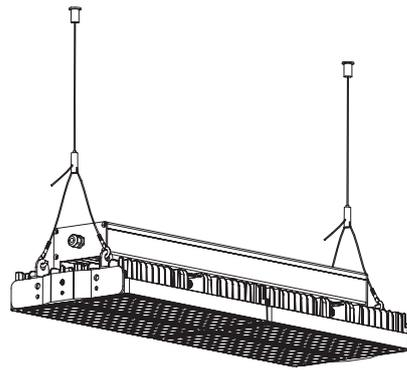

Parameter

Model No.	SPE-MHB-150H	SPE-MHB-200	SPE-MHB-300	SPE-MHB-400
Input Voltage	100-305VAC	100-305VAC	100-305VAC	100-305VAC
LED Power	150 W	200 W	300 W	400 W
System Power	165 W	220 W	330 W	440 W
Luminous Flux	21,400 lm	26,800 lm	39,600 lm	57,000 lm
System Efficacy	130 lm/W	130 lm/W	130 lm/W	130 lm/W
Beam Angle	30°x30° / 60°x60° / 90°x90° / 30°x100° / 50°x140° / 40°x140° / 30°x140° / 140°x140°			
CCT (K)	4000 / 5000 / 6500	4000 / 5000 / 6500	4000 / 5000 / 6500	4000 / 5000 / 6500
CRI	80	80	80	80
Dimmable	1-10V / DALI	1-10V / DALI	1-10V / DALI	1-10V / DALI
Power Factor	> 0.90	> 0.90	> 0.90	> 0.90
Lifespan	50,000 H	50,000 H	50,000 H	50,000 H
Operating Temp.	-40°C ~ + 40°C	-40°C ~ + 40°C	-40°C ~ + 40°C	-40°C ~ + 40°C
Module Quantity	3	3	4	6
Weight (kg)	-	-	-	-
Certifications	CE, CB, SAA, ETL	CE, CB, SAA, ETL	CE, CB, SAA, ETL	CE, CB, SAA, ETL

Photometrics

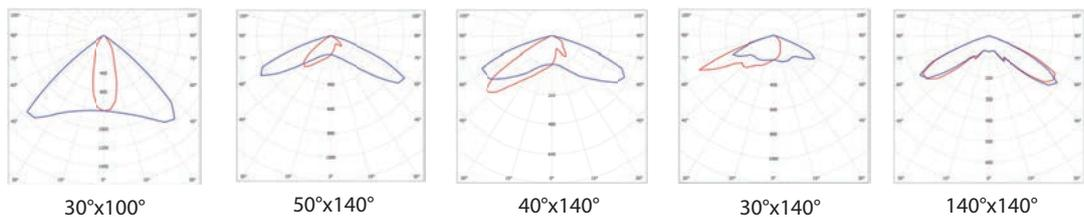

Dimensions (mm)

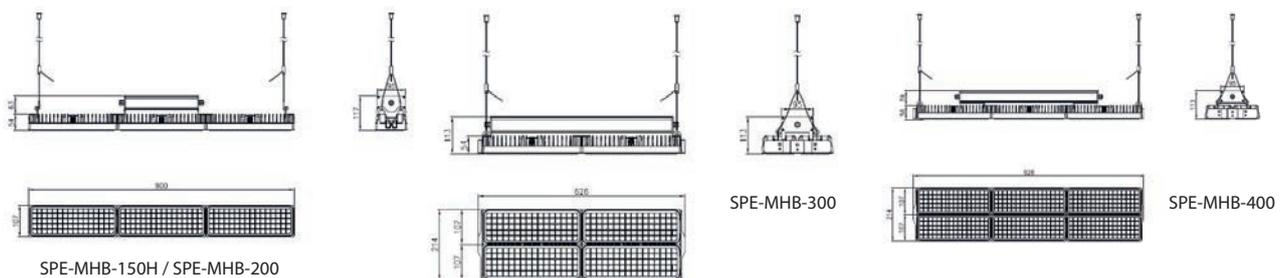

PANDORA Canopy Light Series SPE-MCA

IP65 Available from 50W to 200W

Flood Light is ideal for:

- * Petrol stations
- * Parking garages
- * Storage facilities
- * Industrial facilities

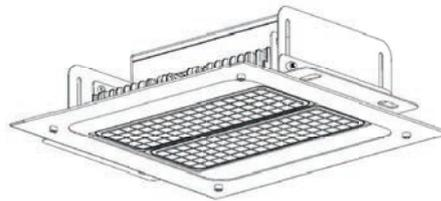

Parameter

Model No.	SPE-MCA-050	SPE-MCA-075
Input Voltage	100-305VAC	100-305VAC
LED Power	50 W	75 W
System Power	55 W	80 W
Luminous Flux	7,100 lm	9,600 lm
System Efficacy	130 lm/W	130 lm/W
Beam Angle	30°x30° / 60°x60° / 90°x90° / 30°x100° / 50°x140° / 40°x140° / 30°x140° / 140°x140°	
CCT (K)	4000 / 5000 / 6500	4000 / 5000 / 6500
CRI	80	80
Dimmable	1-10V / DALI	1-10V / DALI
Power Factor	> 0.90	> 0.90
Lifespan	50,000 H	50,000 H
Operating Temp.	-40°C ~ + 40°C	-40°C ~ + 40°C
Module Quantity	1	1
Weight (kg)	-	-
Certifications	CE, CB, SAA, ETL	CE, CB, SAA, ETL

Photometrics

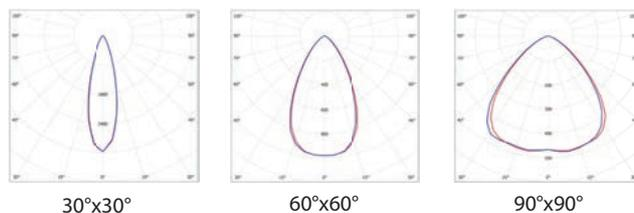

Dimensions (mm)

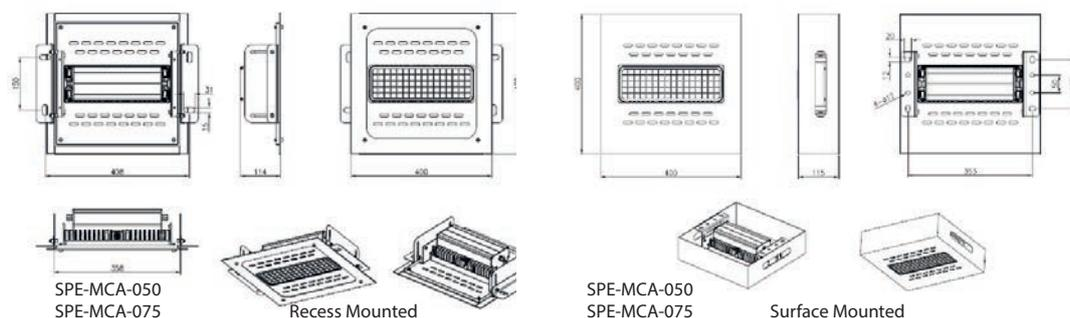

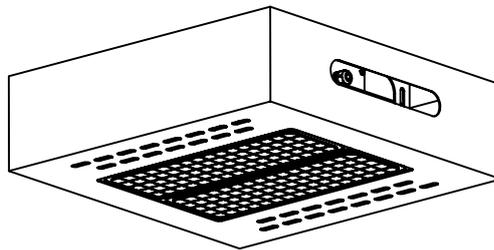

Parameter

	SPE-MCA-100	SPE-MCA-150L
Model No.	SPE-MCA-100	SPE-MCA-150L
Input Voltage	100-305VAC	100-305VAC
LED Power	100 W	150 W
System Power	110W	165 W
Luminous Flux	14,300 lm	19,000 lm
System Efficacy	130 lm/W	130 lm/W
Beam Angle	30°x30° / 60°x60° / 90°x90° / 30°x100° / 50°x140° / 40°x140° / 30°x140° / 140°x140°	
CCT (K)	4000 / 5000 / 6500	4000 / 5000 / 6500
CRI	80	80
Dimmable	1-10V / DALI	1-10V / DALI
Power Factor	> 0.90	> 0.90
Lifespan	50,000 H	50,000 H
Operating Temp.	-40°C ~ + 40°C	-40°C ~ + 40°C
Module Quantity	2	2
Weight (kg)	-	-
Certifications	CE, CB, SAA, ETL	CE, CB, SAA, ETL

Photometrics

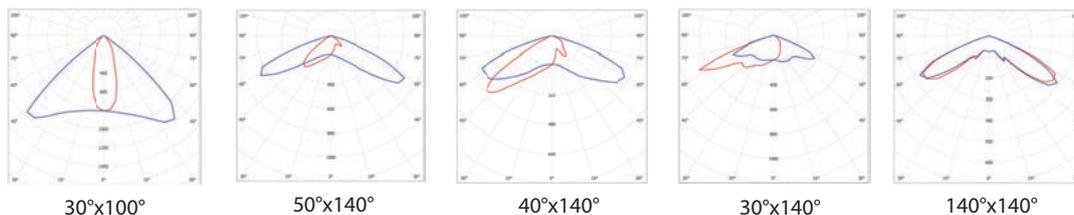

Dimensions (mm)

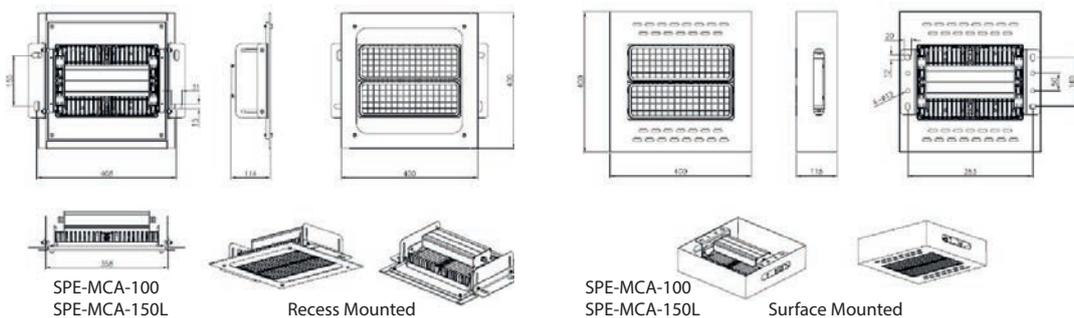

PANDORA Canopy Light Series SPE-MCA

IP65 Available from 50W to 200W

Canopy Light is ideal for:

- * Petrol stations
- * Parking garages
- * Storage facilities
- * Industrial facilities



Parameter

Model No.	SPE-MCA-150H	SPE-MCA-200
Input Voltage	100-305VAC	100-305VAC
LED Power	150 W	200 W
System Power	165 W	220 W
Luminous Flux	21,400 lm	26,800 lm
System Efficacy	130 lm/W	130 lm/W
Beam Angle	30°x30° / 60°x60° / 90°x90° / 30°x100° / 50°x140° / 40°x140° / 30°x140° / 140°x140°	
CCT (K)	4000 / 5000 / 6500	4000 / 5000 / 6500
CRI	80	80
Dimmable	1-10V / DALI	1-10V / DALI
Power Factor	> 0.90	> 0.90
Lifespan	50,000 H	50,000 H
Operating Temp.	-40°C ~ + 40°C	-40°C ~ + 40°C
Module Quantity	3	3
Weight (kg)	-	-
Certifications	CE, CB, SAA, ETL	CE, CB, SAA, ETL

Photometrics

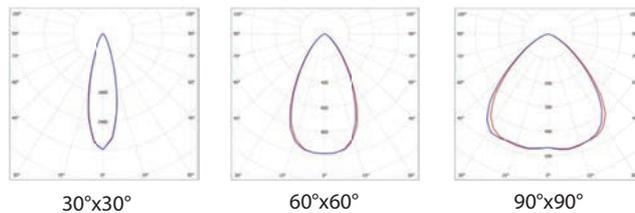

Dimensions (mm)

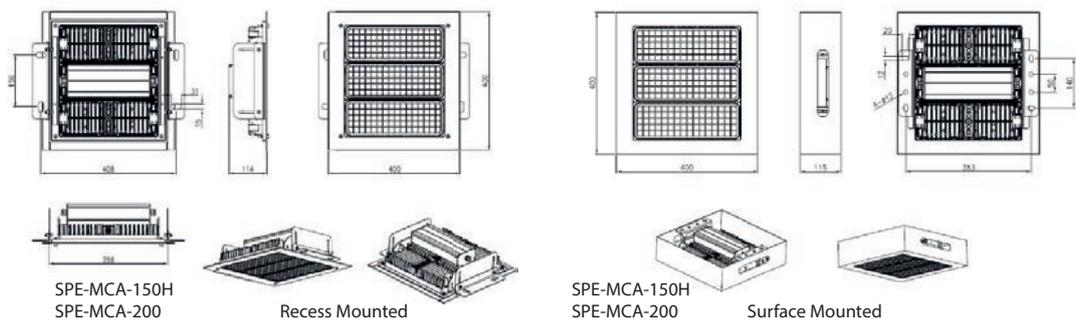



Accessories

Canopy Light Series SPE-MCA

Sensor compatible

Optional microwave or passive infrared sensor available

Mounting

Recessed or surface mounted installation options

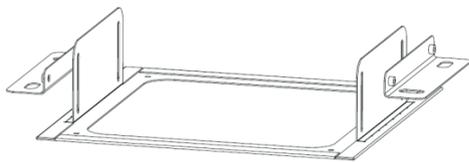

Recess Mounted

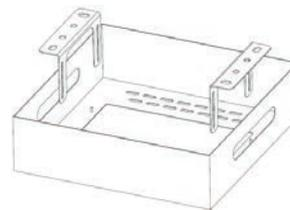

Surface Mounted

Photometrics

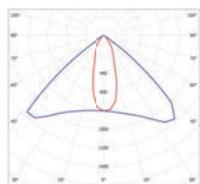

30°x100°

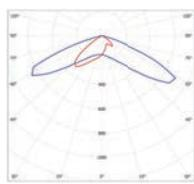

50°x140°

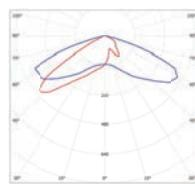

40°x140°

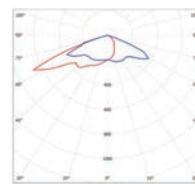

30°x140°

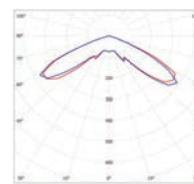

140°x140°

SpektraLED Lichtsteuerung

mit Funktechnik (ZigBee 2,4 Ghz)

Um auf der einen Seite Energie zu sparen und auf der anderen Seite die Lichtverhältnisse für die Menschen, die in einem bestimmten Bereich arbeiten zu verbessern, werden heute viele bestehende Gewerbe- und Industriebeleuchtungen durch moderne LED Leuchten ersetzt. Durch die Erweiterung der LED Leuchten mit intelligenten Sensoren, kann der Energieverbrauch weiter gesenkt werden.

Sensoren für Tageslicht und zur Erkennung von anwesenden Personen sind verfügbar und können einzeln oder auch in Kombination verwendet werden.

Je nach Anforderung kann man damit Lichtsteuerungen erstellen, deren Funktion die Lichtverhältnisse nach dem Tageslicht optimiert und dies zum Beispiel nur dann, wenn sich Personen im Bereich aufhalten.

ZigBee ist eine Spezifikation bzw. ein weltweiter professioneller Standard für drahtlose Netzwerke mit geringem Datenaufkommen und baut auf dem IEEE 802.15.4 Standard auf. Der Schwerpunkt von ZigBee liegt in Netzwerken mit kurzer Reichweite (10 bis 100 Meter). Durch die Verwendung der Mesh-Funktion, bei der alle Funkknoten auch untereinander kommunizieren, sind dadurch Reichweiten von mehreren Kilometern möglich.

Tageslichtsteuerungen können ohne zusätzlichen Verkabelungsaufwand ganz einfach und kostengünstig realisiert werden. Bestehende Leuchten können mit den verfügbaren Komponenten ebenso ausgestattet werden. Die einzige Voraussetzung, die Leuchten müssen dimmbar sein (PWM oder 1-10V).

Lediglich der Tageslichtsensor und der Controller benötigen eine Spannungsversorgung. Die dimmbare LED Leuchte wird an die bestehende 230V Spannungsversorgung angeschlossen. Der Tageslichtsensor kommuniziert mit dem Controller und mit den Leuchten.

Die Lichtsteuerung kann mit folgenden Bussystemen verbunden werden:



EnOcean

Für die Kommunikation mit übergeordneten IT-Systemen steht die sehr flexible und leistungsstarke Anbindung an Node-Red zur Verfügung. Damit lassen sich hoch innovative Steuerungssysteme mit MQTT Servern, Internet-Kommunikation, Visualisierung in verschiedenen Systemen usw. realisieren.



LED Leuchte mit integriertem ZigBee Controller (bis zu 500 Leuchten in einer Lichtgruppe möglich)

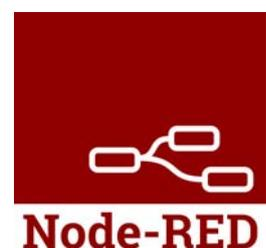

ZigBee Bedienterminal - inkl. SpektraBee Software und Visualisierung

- Erstellen von Lichtszenen und Lichtgruppen auf Windows PC oder Tablet-PC. Abspeichern der Einstelldaten erfolgt auf Datenträger (Festplatte, USB-Stick, Firmen-Server,...).
- Erstellen diverser Lichtgruppen die unabhängig über definierte ZigBee-Tageslichtsensoren auf das gewünschte Beleuchtungsniveau geregelt werden können.
- Erstellen diverser Lichtgruppen die unabhängig über definierte ZigBee-Bewegungssensoren entsprechend gesteuert werden.
- Bedienoberfläche (Visualisierung) zur Änderung von Parametern und zur Anzeige der Leistungseinsparung bzw. des aktuellen Energieverbrauchs.

Zur Konfiguration des Systems und als zentrales Steuerungssystem steht das Software-Paket SpektraBee zur Verfügung, welches auf Windows-PC's und auf LINUX Rechnern läuft!

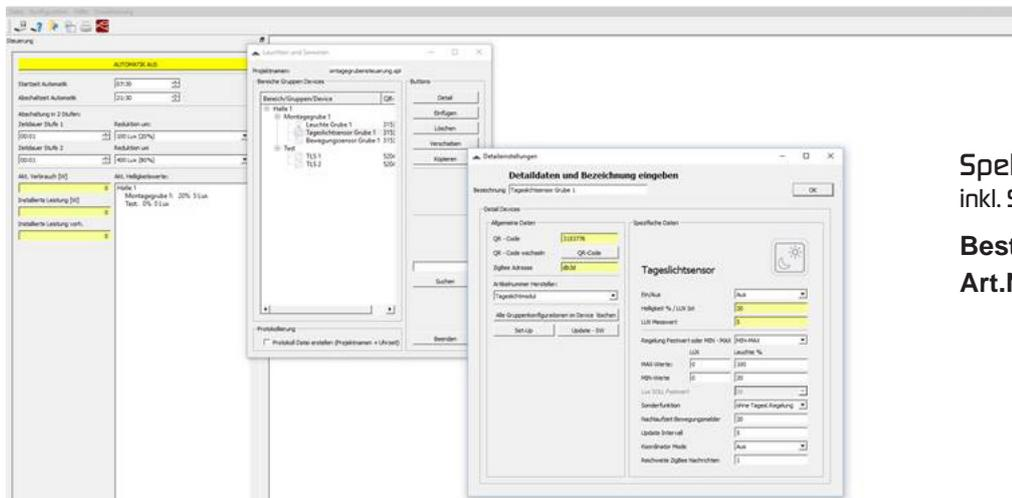

SpektraBee Bedienterminal
inkl. Software & Visualisierung

Bestell-Nr.: 10792098

Art.Nr.: SPE-ZB-LST-WIN10-01



ZigBee Controller (0-10V; IP65)

Bestell-Nr.: 10792050

Art.Nr.: SPE-KZE-734



ZigBee Tageslichtsensor
(je Lichtgruppe wird 1 Stk. benötigt)

Bestell-Nr.: 10792100

Art.Nr.: SPE-SZT-611



ZigBee Bewegungssensor (IP65)

Bestell-Nr.: 10792110

Art.Nr.: SPE-BTS-810

